



4X4 ACTION

PRODUCTS | NEWS | TRAVEL | INFORMATION | ADVICE | LIFESTYLE

| 42



BP-51

THE RULES
HAVE CHANGED

ARB PRODUCTS

We introduce two new additions to our Ascent canopy range, reveal our long awaited Summit bull bar family, the latest recovery gear plus much more.

BP-51

Get the inside info on ARB's new high performance bypass shock absorbers.

TRAVEL

Join us as we explore this great country, from the Top End, across the Great Australian Bight to NSW's South Coast.

Contents



Products

- 6 New Gear from ARB
- 16 BP-51 High Performance Bypass Shock Absorbers
- 38 ARB Next Generation Summit Bar
- 44 ARB Alloy Bar
- 58 New ARB Ascent Canopies
- 62 RK11 Recovery Kit
- 63 Redarc New Battery Management System
- 64 New Redarc 52mm Gauges
- 66 Thule Perspektiv Range
- 68 ARB Water Crossing Cover
- 74 New Bars for ISUZU D-Max and MU-X
- 84 Run Emu Run, Real Life Story
- 88 ARB New Website

Competitions & Promos

- 70 Bushranger Easter Specials
- 86 Win an ARB Tongmaster Apron
- 90 Off the Track Competition
- 91 Scrub Up Competition Winners

Travel & Events

- 8 South Coast Wonderland, NSW
- 32 Across the Bight, SA
- 46 Adventure Australia Treks & Tours
- 48 Kakadu Dreaming, NT
- 87 Eldee Easter Event, NSW



Fundamentals

- 4 Piece of the Action
- 30 Common Thread
- 60 Behind the Shot
- 72 Burnie Store
- 73 What's on
- 76 Photography Tips & Techniques
- 80 ARB Kids

Get Social

Keep track of all the latest ARB news and events on Facebook, Instagram, Twitter and YouTube.



Facebook: ARB4x4 | Instagram: ARB4x4 | Twitter: ARB4x4 | YouTube: ARB4WD



ARB 4x4 Action is also available as a free app on your iPad or Android tablet. Back issues can also be downloaded for free.

Editor: Jessica Vigar

Contributors: David Kirby, Dean Mellor, Jackie Leckie, John Denman, Ken Duncan, Lisa Ingram, Luke Watson, Martin Josselyn, Matt Frost, Michael Ellem, Ron & Viv Moon, Sam Boden.

Graphic Design: Vanzella Graphic Design

Photography: Offroad Images and Mark Lowry Photography

Pre-press: Splitting Image

Printing: Offset Alpine

Prices shown in this magazine are ARB's Australian domestic recommended retail prices inclusive of GST, and do not apply to international markets. ARB reserves the right to amend these prices without notification. In some regions of Australia, additional freight costs can be expected. Prices shown do not include supplementary charges such as fitting or colour coding.

ACTION INSIGHTS

400

Metric tonnes of force used in press forming components of the new Summit Bar range

10,000

Hours of computer aided engineering in the BP-51 development process (including Finite Element Analysis, CAD modeling, application development and prototype testing)

19,804

Size of Kakadu in km² (almost half the size of Switzerland)

36,000

The amount of poles used to construct the Overland Telegraph Line

PLECC
THE
ACTION



Matthew Frost,

National Sales and Marketing Manager

Welcome to the first issue of ARB 4x4 Action for 2015, a year that promises to see a great deal of excitement in the Australian 4x4 calendar.

It was forty years ago that our founder, Anthony (Tony) Ronald Brown, returned from Cape York with a vision that would have an immense impact on the off road scene in Australia and around the world. That vision was to build the very best 4x4 protection equipment possible, and it's an ethos our company has adhered to during its forty year history.

I recently caught up with Neil Cox, an avid remote area adventurer, and a gentleman who claims to be ARB's first paying customer. Back in 1975, following a minor collision, Neil went looking for a bull bar for his 4x4 and heard about this bloke who had just started knocking up protection equipment out of his garage. Neil vividly remembers collecting that first bull bar one evening after work, and the ensuing friendship that developed between him and Tony Brown. Neil gave me a fascinating account of those early days at ARB, and provided an insight into the absolute passion for perfection that was one of Tony's traits. He recounted a story of Tony absolutely cracking it with his colleagues, when it was suggested that ARB should develop a budget line of gear to sell alongside the premium accessories the company was forging a reputation for. Tony had absolutely no interest in compromise, and just wanted to build the highest quality product he possibly could.

Of course these days we're very focussed on delivering value for money with our products, and modern manufacturing techniques have gone a long way to achieving this. But that original guiding philosophy of putting functionality, reliability and durability above all else, is very much a principle we continue to adhere to at ARB.

As we prepare to celebrate our 40th anniversary, there are a number of activities we are planning that we would love to see our customers get involved in. I mentioned in the last issue of this magazine that we frequently get asked for our views on the best 4WDs out there, so we're going to settle this debate once and for all. As part of our 40 year celebrations, we'll be asking our customers, staff and distributors for their views on the most influential off road vehicles that have been released over the past four decades. We'll then narrow this down to four, buy them, restore and accessorise them, and then head bush to put them through their paces. Keep an eye on ARB's website and social media channels to be part of the fun.

One big event that's already been and gone is a 40 year anniversary conference we recently ran for all of the ARB store managers from around the country. The event was held in Melbourne, and like most conferences, kicked off with the obligatory bunch of Powerpoint presentations and pie charts. With the humdrum formalities out of the way, we were able to get into the fun stuff and revealed a number of exciting new product launches for 2015. The first of these, the

stunning new BP-51 shocks, are featured later in the magazine. We then hit the town for an exceptional evening at the Lindsay Fox car museum. This provided us with the perfect opportunity to recognise and thank many of our distributors and staff in the room with some outstanding achievement awards. There were many deserving winners, but a standout that really warrants attention is our store of the year, ARB Hobart. The entire crew there do an absolutely sensational job of representing ARB, and live and breathe our company's philosophy of, "how can we do it better?"

Tony Brown moved on from ARB many years ago, but his brothers Roger and Andy, both company Directors, joined our crew for the weekend and entertained us with stories from the past, and provided inspiration with their vision for the future.

Today there are over 1,300 staff directly employed by ARB, and many thousands more who are employed by our distributors and suppliers. Most of us have never met Tony Brown, but I reckon there would be a large number of us who would like to shake his hand, buy him a beer and say 'well done mate'.



GEAR

UP

ARB'S RANGE OF APPAREL AND PROMOTIONAL GEAR WILL BE SURE TO KEEP YOU IN STYLE AND READY FOR ANY ADVENTURE.

① OVERLAND ZIP-UP & PULL OVER HOODIES

Adding to ARB's extensive apparel range, these new Overland Hoodies are ideal for all your outdoor adventures. Gunmetal grey brushed fleece with a subtle black ARB logo across the chest, these stylish jumpers include bonded mesh panels and the signature 'ARB red' hood lining. With YKK zips and rubber moulded logo zip pulls (zip-up version only), these threads will complement just about everything in your wardrobe.

Part no. 217591 to 217597
RRP \$79.50

② ARB ESCARPMENT DRINK BOTTLE

Stay hydrated on any adventure with ARB's new stainless steel drink bottle. Incorporating a black matte finish and gloss printed ARB logo, the drink bottles are complemented with a white printed 'escarpment' rocky line. Holding 750ml of fluid, the ARB drink bottle is the must-have journey companion.

Part no. 217431
RRP \$13.99

③ TONGMASTER APRON

Bring out the bbq master in you with ARB's latest must-have accessory. Made from a navy blue washed canvas and yarn dyed poplin lining, the front of the Tongmaster Apron features a stylish 4WD cut chart print and ARB leather embossed badge. Adjustable straps for 'one size fits most' and multiple front pockets for all your cooking essentials. A great gift idea for the aspiring grill master!

Part no. 217604
RRP \$44.95



①

②

③

SOUTH WONDER



**KEN DUNCAN INTRODUCES US
TO ONE OF NEW SOUTH WALES'
BEST KEPT SECRETS, THE
BEAUTIFUL SOUTH COAST.**

Words and Photography
by Ken Duncan

COAST IRLAND

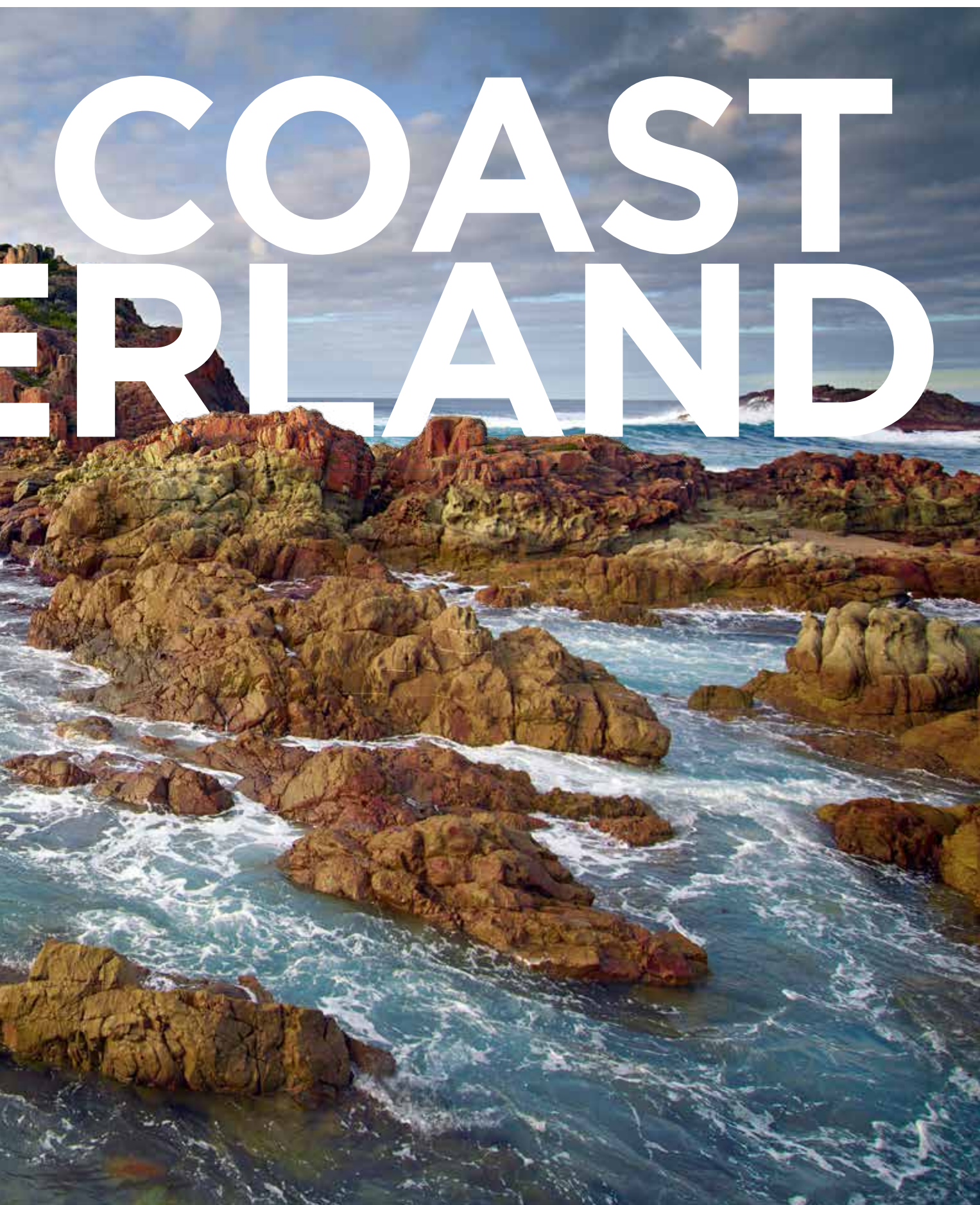



FOR ME, THIS WAS A DREAM ASSIGNMENT – BEING PAID TO FIND EXOTIC LOCATIONS.

When asked what my favourite place to photograph is, I will always say Australia. It still has so many hidden or little-known treasures that continue to surprise me. We all need balance in our lives and I find that taking time out to enjoy creation helps put things into perspective. I love each of the different states and territories of our great southland – they offer tremendous diversity for anyone who loves natural beauty.

Many areas of our country have their own individual personality and unique wonders. What amazes me is that one of our most diverse and beautiful states is often sold short for its breathtaking vistas. What state would this be you ask? Well here are a few clues: its capital city is like a vortex that tends to draw everything into itself; it has an Opera House that resembles a sailing ship tied up to a wharf; it has a coat hanger for a bridge which is centre stage for a pyrotechnics extravaganza to usher in each new year with declarations such as Peace or, this year's

message; Inspire.

Yes, you guessed it: New South Wales. Sydney is a sensational city blessed with sapphire waterways, fringed with idyllic golden beaches, and protected from the west by The Great Dividing Range. I love visiting Sydney, but I also love to get away again, as I often need time and space to process the amount of stimulus a city can generate.

This pioneering state has so much more to offer than just Sydney, if you can stand the separation from crowds, glamour and glitz. Let's just leave the city smoke behind for a while and head south, as I want to show you what I believe is one of New South Wales' best-kept secrets. The delightful playground I'm referring to is the area from Batemans Bay south to Eden. Part of this area is referred to as The Sapphire Coast and it truly is a southern coastal wonderland.

I had travelled through this location many years

(Left) Ken Jamieson,
Bates Emporium,
Central Tilba.
(Right) Horse Head
Rock, Bermagui.



ago and knew I would need to spend more time exploring the area. The opportunity came when I was commissioned to take photos to help promote the region. It was a tough job but I was happy to take one for the team (lol). For me, this was a dream assignment – being paid to find exotic locations.

I know Australia pretty well and I'm a resident of NSW, but as I began to explore the region, I was mystified as to why I hadn't heard more about it. There are scenic wonders in this domain that are right up there with many of Australia's most iconic locations – place names that everyone should know like Glass House Rocks, Camel Rock and Mogo Zoo to name just a few. Why had I not heard more about these places? I think Tourism NSW needs to get its act together in promoting this phenomenal area.

Maybe the area has been kept hidden away by locals and travellers who want to preserve their own southern paradise. I actually felt a little conflicted

about sharing this jewel. What eventually helped me was the overwhelming number of locals who convinced me it was time to open the treasure chest for all to share. They need tourism to help create more job opportunities as sadly, out of necessity, many of their youth get sucked into the vortex of city living.

So here we go on a journey of discovery that will hopefully inspire you to explore this jewel of Australia.

Let's start with Batemans Bay and Moruya where there are many accommodation options, from camping to hotels and motels. I found a wonderful base from which to explore the area, called Oaks Ranch & Country Club. It is perfectly situated, nice and close to some great locations. When you wake up in the morning, there are big mobs of kangaroos all over the paddocks. There are horses to ride and a donkey called Keating who will entertain you with his peculiar bray. It's like he's saying, "Hello. What

THE SUN BROKE THROUGH AS IF TO SAY, 'NO TURBULENCE TODAY', AND THE STORM TURNED AWAY AND HEADED NORTH.



you up to? Can you spare me a carrot?" The couple that manage the property are really lovely people and treat you like family (a properly functioning one). A good place is even more appealing when people are welcoming and friendly, and keen to ensure you have a great time. To top off the experience, they do a hearty breakfast, which is always a great way to start the day.

Batemans Bay is a small coastal town with all the amenities and services you require. There are many beach locations nearby to visit but one of my favourites was Shark Bay at Broulee. I loved this place. The beach is quite secluded and protected from rough seas, and if you can make it there for sunrise, you're in for a real treat. There were only two other people on the beach this particular morning. As I was waiting for the sun to rise, a big storm came rushing in from the ocean. Just before the awe inspiring squall hit land, threatening to drench me with rain, it stalled and there was a calm. The sun broke through as if to say, 'no turbulence today', and the storm turned away and headed north. A rainbow appeared as a sign of peace in the trailing rain.

One place you must visit is Mogo. The coastal highway

runs right through the town and an eclectic mix of shops cling to this lifeline of potential customers. From some of the colourful clothing shops I saw, I thought I had been time warped back to the 1970's. You will love this little food and shopping haven. Spending hours taking it all in but beware: very few people leave without succumbing to some temptation. Mogo also has what I consider to be one of the best zoos in Australia. When I first saw the sign for Mogo Zoo I thought, "They have to be kidding. This will be dinky". I planned to avoid it, until my newly adopted Mum at Oaks Ranch told me I would be an ass along with Keating if I missed it. Mogo Zoo is privately owned and run by Sally Padey and her fantastic staff. I was with my wife, Pam, who loves wildlife and convinced me to go along. We were amazed at the diversity of animals and how well everything was set up. This zoo has real personality and reminds me of the movie, "We Bought a Zoo", starring Matt Damon. Running a zoo is a lot of hard work, but Sally's team are more like co-conspirators than staff. They are all effervescent in sharing their passion for wildlife. If I was an animal and had to live in a zoo, I would definitely hang out with Sally. If you want to learn more about wildlife photography, this is an awesome place to go. You



can join June Anderson for a photographic workshop called Mogo Zoom, but you must book ahead as they are really popular.

Moruya is another interesting town. Moruya Thai is one of the best Thai restaurants I've ever been to. Just south of Moruya is Mullimburra Point, which provides some gorgeous ocean landscapes. I was amazed by the place many locals call 'The Pinnacle'. As it faces the onslaught of the swirling sea, this formation seems like an arrow pointing to heaven as a reminder for us to look beyond our own limitations.

Time to move base south to Narooma, as there is so much still to see. There are many places to stay in town on the Wagonga Inlet. The town also has a great bakery with excellent pies. Narooma has a formation known as Australia Rock, which is a good location for the mandatory family happy snap. The key is to get the subjects to balance in the rock opening (in the shape of Australia), without falling or getting hit by big waves.

Not far from Narooma is an intriguing coastal formation called Glasshouse Rocks. I spent a couple of days waiting for the right light in this location and

was amazed at how few people I saw. It obviously impressed Captain Cook on his discovery of Australia, as he apparently gave the area its title. To me this setting is an icon waiting for its day in the spotlight. Move over Twelve Apostles - we are more user friendly and welcome to all.

Other places I visited from my Narooma base were Tilba and Camel Rock down near Bermagui. On the way to the Tilba area, you pass picturesque Corunna Lake, a great place to canoe or swim in the fresh water.

Central Tilba, a charming, working heritage village, classified under the National Trust, has been named as one of Australia's top 20 heritage sites. That alone makes it well worth a visit. There you will see a thriving arts and craft centre where local artisans such as wood-turners, glassworkers, jewellers, artists and winemakers within 19th century weatherboard cottages, continue the creative traditions of early settlers.

Some of my favourite stores were The Lolly Shop and Bates Emporium Store, which generally had everything, including irresistible Tilba Fudge. If you



TO ME THIS SETTING IS AN
ICON WAITING FOR ITS DAY
IN THE SPOTLIGHT.

think you are tough enough to resist temptation I dare you to go into these two shops and come away without any calories in your bag. I figure that if you give out sweetness in life, you need to replenish your sugar levels so you can give out more!

This southern area certainly rocks and now we visit Camel Rock and Horse Head Rock, which are close to each other. If you view Camel Rock from the south end, it looks like a camel – hence the name. However, the most commonly photographed side is the northern side and I will let you decide what that looks like. Just a few hundred metres north is Horse Head Rock. The best view of it is looking south. Please be very careful around this whole area. Be aware of what is happening with the tides and sea conditions, so you don't get trapped between tides or hit by big rogue waves.

Time to change bases again and head inland a bit to Bega. Everyone 'say cheese!' A visit to the Bega Cheese Heritage Centre is very interesting - and educational. But Bega is more than just a cheese town and the home of our number one Australian cheese brand. Beautiful rolling hills and enticing rural landscapes surround the town. Cows are scattered all over the verdant pastures. It is miraculous to me how cows turn green grass into white milk. If

you're taking photos near fences, please take care, as they may be electrified. Inadvertently touching one of those is certainly one way to get an early morning kick-start. I did this while shooting cows in the mist. I got the mist but missed seeing the electric wire – ouch!

If you are looking for nightlife, then Bega may not be your best location. You could shoot a cannon down the main street at 10pm and hit nothing. The local pub has great food and I'm sure there is nightlife somewhere in the town. You will have to ask the locals but the local pub can often be a good place to meet your new best friend in any town.

While based at Bega, I headed down to Mimosa Rocks for sunrise and sunset as it is only about 50 minutes away. Watch out for wildlife on the roads if you're travelling in the dark! At Mimosa Rocks you need to take your time and really look around, as there are many coves and many angles to view. Don't just do the old routine of walking to the viewing platform, saying, "Wow that's nice", and taking a selfie to tick it off your list. Invest some time to stop and look around so you can really explore the place. As you do, it will unlock its secrets to you. Now it's time to head south again down the coast and set up a new base camp at Merimbula. This is a great little

(Left) Glasshouse
Rocks, Narooma.
(Right) Australia Rock,
Narooma.



town and a holiday playground for many Mexicans (Victorians) that come from south of the border. I can say that without getting into too much trouble, because I was born in Victoria.

It was good to be in this town as I caught up with some old friends. The test of great friendship is that when you catch up, even if it has been years since you've seen them, it's as if you pick up the conversation just where you left off last.

From Merimbula there is so much to explore, all the way down to the fishing town of Eden. Some of the beaches in this area are stunning, like Bar Beach, just to name one of the many.

It is a great pleasure to share this adventure with you. I have approached this article from a scenic point of view. There are many more attractions I could have spoken of, but I'm sure you will add to this starting point. Those who enjoy many other facets of travel will also have a memorable time. The region has endless opportunities: fishing, surfing, yachting, boating, golfing and bushwalking are just some of the many possibilities. One of the few things this area doesn't offer is snow skiing, so leave the skis behind. Artistically, there is more freedom to operate in this area, with greater access than many other places

that bask in the glory of being big Australian icons. Often, with fame comes over-zealous bureaucracy. I do hope by calling these places paradise, we don't kiss them goodbye as The Eagles sang in their song, 'The Last Resort'.

We all need connection to the land and the more places we make available for people to share, the more pressure we take off individual areas. But with knowledge comes responsibility. Enjoy these areas and be a blessing to the locals. Let's keep this southern paradise intact for future generations to enjoy. This coastal strip is unquestionably another jewel in our Australian crown.

So before we return once more to our daily realities, let's finish this expedition at North Tura Beach, a favourite spot for Merimbula locals and visitors. It is an intoxicating place to stop and ponder life. As the waves come and go and clouds sail on by, it inspires us to dream and not be held back by the worries life can bring.

So southern dreaming you should go and enjoy the journey that unfolds.



MISSION: CONTROL

Words by **Dean Mellor** Photography by **Offroad Images**

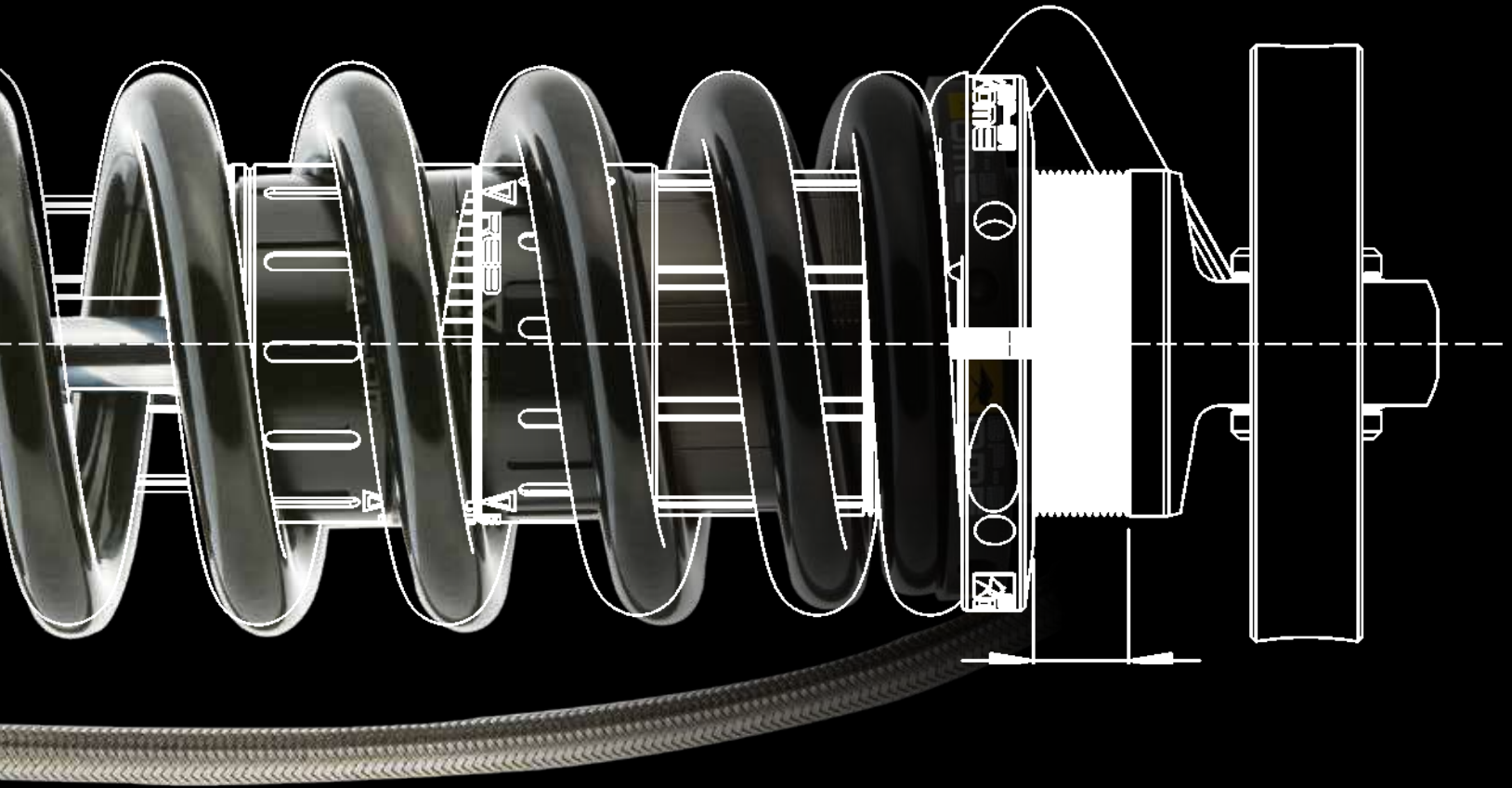

THE ALL NEW BP-51 IS A
REVOLUTIONARY FOUR WHEEL DRIVE
SUSPENSION SYSTEM THAT DELIVERS THE
ULTIMATE COMFORT AND CONTROL,
BOTH ON THE ROAD AND OFF.



ARB has developed what is possibly the most advanced shock absorber on the market, anywhere in the world, and it's called BP-51.

This is a big claim but when you look at the technology built into BP-51 – the research, development and testing behind it; the unique way in which it's been manufactured; the unequalled performance that it delivers when fitted to any number of four wheel drives; and the scope of adjustability that it offers – there really is no argument: this new shock absorber is as good as it gets.

BP-51 is a bypass shock absorber with a 51mm bore size, hence its name. This revolutionary new shock absorber looks like nothing else on the market thanks to its hard-anodised aircraft grade 6061 T6 aluminium body and remote reservoir. And it performs like nothing else on the market, thanks to its clever internal bypass position-sensitive technology, its adjustable spring preload/ride height, and its adjustable compression and rebound damping.

To top it off, BP-51 is supplied with vehicle-specific mounting hardware, brackets and tuning, for either live-axle four wheel drives or, more significantly,

the growing number of coil-over independent front suspension (IFS) four wheel drives on the market, allowing for easy fitment to a range of vehicles.

To put BP-51 through its paces, ARB invited me to drive from the company's HQ in the Melbourne suburb of Kilsyth, Victoria, all the way to Eldee Station, out past Silverton in Outback NSW, more than 900km to the north. This allowed me to sample the new shock absorbers on close to 2,000km of blacktop, while also giving me four days of driving on rough gravel roads, station tracks and rocky off road terrain.

We had three vehicles on test: a Ford Ranger, a Toyota Prado and a Toyota LandCruiser 79 Series. And this mix of vehicles was critical to the driving experience with BP-51 shock absorbers, as both the Ranger and the Prado feature the aforementioned coil-over IFS, while the LandCruiser 79 has a more traditional live-axle set-up with coil springs.

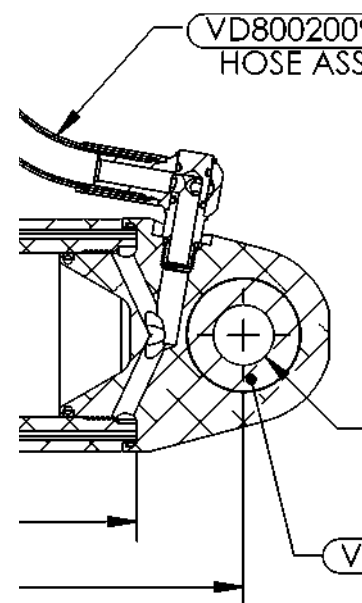

PERFORMANCE



Before we get stuck into the technical nitty-gritty, I bet you really want to know how BP-51 performs, on the road and off it. Put simply, it's amazing!

On road ride and handling is significantly improved, as BP-51 not only offers better vehicle control through progressive damping but also better comfort. In other words, the vehicle can be set-up to corner with less body roll and less fore and aft pitching without adversely affecting ride quality.

This is achieved via BP-51's innovative internal bypass position-sensitive technology, which offers comfortable damping characteristics at normal ride height and significantly firmer damping as the suspension compresses or extends, as is the case when the vehicle drives over undulations or bumps. The result is the Holy Grail of suspension performance: sporty handling without the hard and harsh vehicle ride associated with a firm suspension set-up.

Another big advantage of progressive damping is that the suspension is less likely to slam into the bump stops when you hit an obstacle, such as a washout on a gravel road or a sharp step-up when driving off road. This is because, unlike a normal velocity sensitive shock absorber, BP-51 offers up to 300 per cent more damping in the end zones of shock-travel than it does at static ride height. In other words, as the suspension compresses under load or extends when rebounding, damping performance firms up significantly to lessen the chance of bottoming out or topping out. This means a more compliant ride over rough surfaces as well as improved control.

This type of progressive damping has obvious benefits in off road conditions where the suspension is constantly subjected to full compression and full extension as the vehicle travels over uneven surfaces. But BP-51's bag of tricks doesn't finish there; it also allows you to easily and independently adjust the compression and rebound damping on the vehicle as conditions dictate. In other words, at the end of a long drive along the blacktop to

your favourite off road destination, you can simply firm up the damping to better suit difficult off road conditions using the C-spanner provided with BP-51. And when I say easy, I mean it takes no longer than airing down your tyres thanks to the 10 clearly marked settings on each adjuster.

Once the damping has been firmed up, it's quite amazing how well BP-51 soaks up big obstacles off road. Driving around Eldee Station I had to constantly remind myself that there was little need to slow down before hitting big washouts, step-ups or dry creek crossings, even when behind the wheel of the Ranger or the Prado with their limited-travel coil-over IFS set-ups. Had I been driving these vehicles at speed with their standard springs and shocks, or even any number of traditional mono-tube or twin-tube aftermarket spring and shock kits, there's no doubt that the suspension would've bottomed out, resulting in a harsh and uncomfortable ride. This would particularly be the case in a standard Prado with its traditionally soft suspension set-up, but with BP-51's fitted, even the Prado maintained its composure and comfort over big obstacles.

And then there's the LandCruiser 79. On this vehicle the off road performance offered by BP-51 shock absorbers is phenomenal. The longer travel of the Cruiser's suspension, combined with the progressive damping of BP-51s, meant that it could be driven through deep ruts or over rocky obstacles at astounding speeds.

While BP-51 allows you to drive at a faster pace than you otherwise would, both on and off road, this is not the intention of this innovative new shock. But as we all know, there are often unexpected obstacles when driving, especially on gravel roads or off road, and in these circumstances BP-51 will outperform all but the most bespoke hand-built racing shock absorber set-ups.

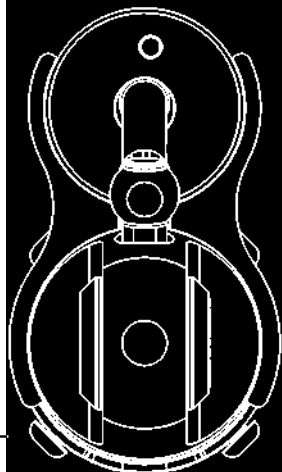

90
Y

Ø19

D50010040
BUSH

THE RESULT IS THE HOLY GRAIL
OF SUSPENSION PERFORMANCE:
SPORTY HANDLING WITHOUT
THE HARD AND HARSH VEHICLE
RIDE ASSOCIATED WITH A FIRM
SUSPENSION SET-UP.

DEVELOPMENT

The BP-51 story started some four-years ago when ARB decided it needed to develop a new shock absorber to cater to the growing number of four wheel drives on the market equipped with coil-over IFS. Examples of such vehicles include Toyota LandCruiser 200 Series, the aforementioned Prado and all of the popular current-generation four-wheel drive utes, such as Toyota HiLux, Ford Ranger, Mazda BT-50 and the upcoming Nissan Navara D23.

Compared to live-axle equipped vehicles such as the 70 Series LandCruiser, Nissan GU Patrol and Jeep Wrangler JK, these coil-over IFS vehicles have relatively limited suspension travel, dictated in part by the length of their suspension arms. While this isn't an issue on the road, it can result in a harsh feeling off the road as the suspension hits obstacles and quickly reaches full compression (hitting the bump stops) and then rebounds to full extension (topping out).

Stuart Fooks, OME Lead Engineer in charge of the BP-51 program, explains this problem in more detail. "With a coil-over IFS, the shock absorber is mounted halfway up the suspension arm so there's less travel at the shock absorber, giving a shorter amount of travel to stop the shock absorber before the bump stop, or to stop it before it reaches full extension.

"Typically, with a traditional velocity sensitive mono-tube or twin-tube shock absorber, if you want to stop slamming into either ends of the travel, you

put firmer valving in the shock. But the downside is that for the majority of your driving, at normal ride height, the suspension is then way too firm and bone jarring.

"You want to have enough control so that you're not crunching into the bump stops, but then you want to valve the shocks soft enough so that you're getting a comfortable ride. That's the trade-off.

To find a way to overcome this trade-off, between ride comfort and control, ARB gave its engineers a clean sheet of paper to design an all new shock absorber. "We had a blank canvas, driven by the fact that ARB was going to manufacture the new shock in-house," says Stuart. "We weren't constrained by going to another shock absorber manufacturer, or designing the shock and then trying to find someone to manufacture it. It was a brand new and fresh sheet from ARB."

Early on in the design process, it was decided that bypass position-sensitive technology was the best way to overcome the inherent problem of a coil-over shock absorber's limited travel, while still being able to deliver the desired ride comfort. This technology would also easily translate to live-axle vehicles, offering the same benefits.



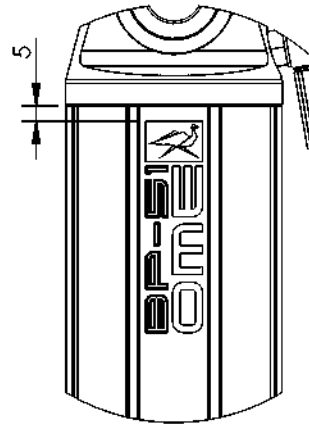
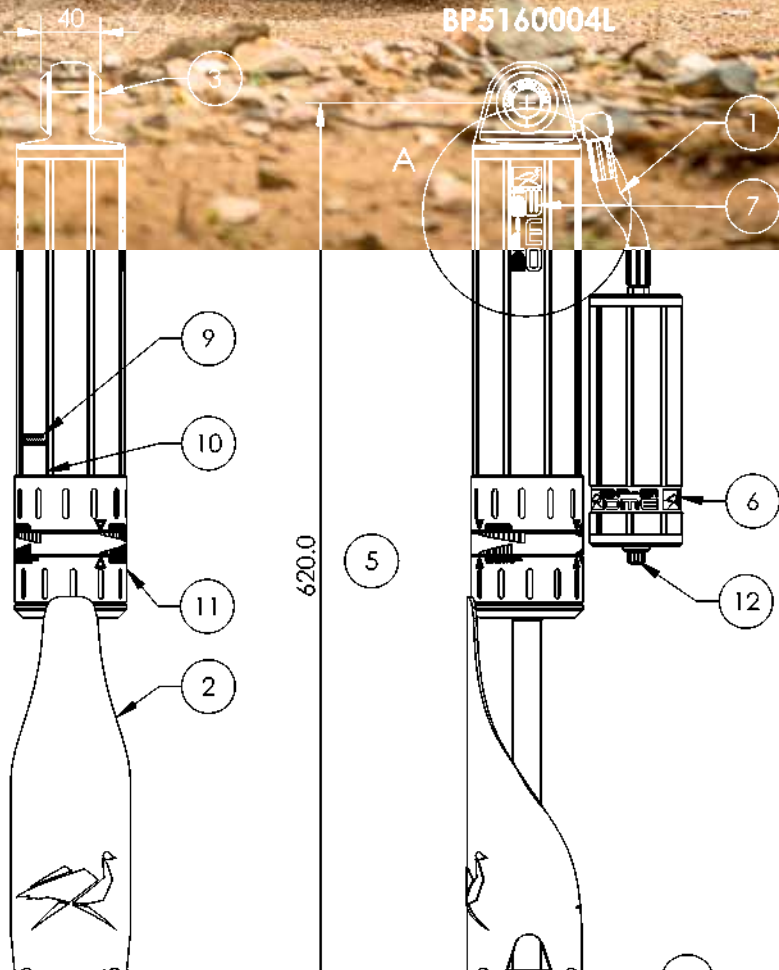

DETAIL A
SCALE 2 : 5
BODY DECAL POSITION

THE BYPASS ADVANTAGE

Unlike a traditional velocity sensitive shock absorber, in which damping force is determined by the shock speed, bypass position-sensitive technology means the shock absorber automatically delivers differing damping force throughout its stroke. In fact, the damping force at full compression or full extension can be up to 300 per cent more than at static ride height, preventing the shock from slamming into the bump stop or from topping out (see page 24: Suspension tech).

In traditional bypass position-sensitive shock absorbers, oil is diverted around the shock's piston and into external tubes, but this presented another problem for the ARB engineers who wanted the shock to be compatible with today's popular coil-over IFS vehicles. The question Stuart and his team had to answer: "How do we fit it all inside a coil spring?"

It didn't take the BP-51 design team very long to come up with the idea of an internal bypass system, diverting the oil around the piston through holes drilled into the inside of the shock bore, and then through internal galleries in the shock body. This is truly revolutionary technology and is also one of the main reasons BP-51 has an extruded aluminium body, and why it is able to incorporate bypass position-sensitive technology without the tell-tale external tubes of traditional bypass shock absorbers used in off road racing applications.

"With an extrusion, we've been able to put those bypass tubes inside the shock body and physically make it work," explains Stuart.

To build a traditional bypass shock absorber for a racing application requires a lot of manual work. "To hand build a steel shock and weld tubes on at different points, and drill holes in different things, and then hone it and get all that right, there's a lot of effort in that," says Stuart. "I think it's a clever solution to produce this technology the way we have, and package it so that it will fit inside the strut tower or the spring bucket, or whatever you want to call it, on the chassis."

According to ARB's Marketing Communications Manager, Sam Boden, this clever packaging of BP-51 could present some confusion in the marketplace. "A lot of people look at the shock and don't immediately think it's a bypass," says Sam. "Most people would think of a bypass shock as your high-end race shock that has tubes external of the shock; while we're using the same technology, it's all been bundled in the shock, and that's why it doesn't look like a typical bypass shock."

"The whole premise behind BP-51 is that it's race technology but it's been cleverly packaged for everyday four wheel drivers and four wheel drives... and everyday four wheel drives these days have a coil-over front end and limited travel, so it's been developed around bringing all of that racing technology and making it fit through clever manufacturing and design."

If the 'BP' in this revolutionary new shock absorber's name stands for bypass, what's with the '51'?

"From the word go, this technology had to be made to fit inside a coil-over," explains Stuart. "There's a limit to how big you can make a coil spring; you've got to make it as big as you can but if you go too big it's going to rub on the chassis or it's going to touch the top arm. Obviously we made the spring as big as we could but then we had to fit this shock body inside the coil spring with a bit of a gap, so it wouldn't rub under spring surge or a bit of a buckle. That's how we arrived at our 51mm bore size."

The large 51mm bore diameter has many benefits, such as allowing for maximum oil volume, the ability to tune the shock and to generate maximum force. Oil volume is also maximised thanks to BP-51's remote reservoir arrangement, which relocates the floating piston and gas from the main part of the shock body to the separate reservoir mounted elsewhere on the chassis. This also maximises the compressed length of the shock absorber.



REFER TO
BP519
HOSE O

ADJUSTABILITY

Another distinctive feature of BP-51 is the ability to independently adjust the compression and rebound damping, both of which can be quickly and easily tweaked on the vehicle as conditions dictate, using the C-spanner provided. This is done by simply reaching under the guard with the C-spanner and turning the dial to the desired setting.

Compression and rebound damping can be independently adjusted through a range of 10 clearly marked settings; an increase in the number essentially increases the stiffness of the shim stack inside the shock absorber body which restricts bypass oil flow, increasing damping throughout the entire stroke.

The damper settings typically are set in the factory prior to shipment to suit vehicles fitted with a bar and winch, but there are setting suggestions for vehicles fitted only with a bar, or those fitted with nothing up front. This is designed to provide the optimum damping comfort and control on smooth to moderate surfaces.

So when would you adjust the damping? Say the road conditions you're travelling along deteriorate and there are deep corrugations and a series of washouts. In this case you might increase the compression damping a couple of clicks and raise the rebound damping by three clicks, giving the shock more resistance to compression and the ability to better control rebound.

BP-51 also features adjustable spring preload so that it can be easily set up at the installation stage to suit vehicles with different accessories fitted.

"The BP-51 fitting instructions list preload settings for given accessory fitments," says Stuart. "They'll explain that the distance from the body cap to the top of the adjustable preload ring should be, say, 20mm for a bar and winch, but if you've just got a bar only then maybe back that back to 15mm, and back to 10mm if you've got no accessories at all. The guys in the factory set it up for a bar and winch, so it's compressing the spring to the greatest extent for the most weight of the accessory fitment, because it's easier to back it off than it is to compress it down."





SUSPENSION TECH

BP-51 is one of the most technologically advanced shock absorbers on the market. Stuart Fooks explains how internal bypass position-sensitive damping works:

“On a compression stroke, fluid flows through the piston as it would in a normal mono-tube shock, but it also flows through one of eight bypass tubes in the outside of the extrusion.

“Four of those galleries, or tubes, are for compression, so on a compression stroke you’re pushing oil through the piston stack, or the valving shim stack on the piston, but then you’re also pushing it – at ride height – through these four compression galleries that are within the body of the shock, but outside of the main bore. That’s how we achieve that comfort at ride height, because the oil is not only going through the piston but around it, in these galleries.

“Then, as the piston moves towards the compression end, it progressively goes past holes between the main bore and that gallery. And so it starts by pushing oil through four galleries as there are four holes open...

“As it progresses it passes one hole at a time and then shuts off that gallery so it goes from having

four bypass passages to three, then to two, to one, to none as it gets to the end zone. In the end zone it’s pushing all the fluid through the piston. So that’s how we create that additional compression damping. It’s pretty much gone from ride height to the end zone with a 300 per cent increase in damping, and it’s had a linear progression.”

There is a similar increase in damping force on the rebound side. “As the shock absorber extends,” explains Stuart, “fluid travels through the piston as well as two of the bypass tubes. The placement of the holes, drilled between the main bore and two bypass tubes, creates five zones of decreasing then increasing rebound damping.

“At its fully compressed position, damping is high to help control the energy of the corresponding highly compressed spring. As the shock absorber extends, the piston travels past one, then two holes to open up bypass passages to reduce rebound damping for comfort at ride height. Then, as the shock absorber continues to extend and the wheel goes into droop, the piston passes two more holes, closing off the bypass passages to ramp rebound into the rebound top-out zone where all oil flows through the piston.”

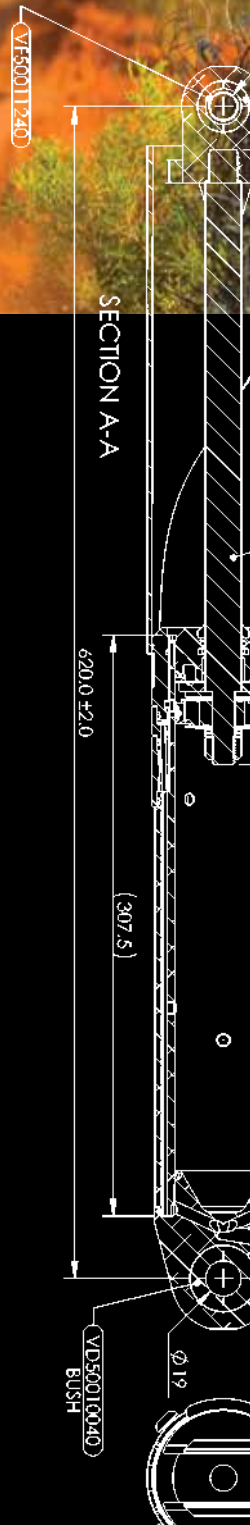

ALUMINIUM ADVANTAGE

Unlike traditional steel-body mono-tube or twin-tube shock absorbers, BP-51 has an aluminium shock body and remote reservoir. The use of this material is a by-product of its complex extruded design, which allows the oil bypass galleries to be cleverly packaged in the shock body to suit the special requirements of coil-over independent suspension vehicles.

"The idea to use extruded aluminium came early in the design process," says Stuart Fooks. "The idea was there, the concept was there, the design was there; probably the biggest challenge then was finding an extruder that could produce the component to the quality that we required to make it all work."

"Then the next thing, we didn't have material constraints, but we wanted to use 6061 T6 aluminium, typically used in the aircraft industry. That, with the complexity of the extrusion profile, made it hard to extrude."

"We could have done it out of lesser (softer) grades of aluminium, because they're easier to extrude and control through the extrusion process, but we hunted around for a few months until we found an extruder that could produce the 6061 T6 aluminium extrusion that we wanted, because that gave us the structural properties of that material grade," says Stuart.

The grade of aluminium is extremely important in a component such as a shock absorber, which is subjected to strong forces throughout its life cycle. The higher the grade, the higher the tensile strength, which means it's harder to pull apart, harder to deform and harder to change its shape, and the extreme testing regime that BP-51 has been put through proves that the use of 6061 T6 aluminium was the right choice.

As well as the complex structure that could be achieved by using extruded aluminium in BP-51, there's another very important benefit: aluminium's excellent heat-dissipating properties.

"The job of the shock absorber is to try and turn kinetic motion into heat and then get rid of it," says Stuart. "Heat is the enemy of the shock absorber. It changes the properties of the oil and also changes the way that it flows through the valving. Typically you can

get fade on twin-tube shocks through generating too much heat and foaming of the oil. The aluminium in BP-51 helps dissipate heat where it's generated from oil flowing through valving, whether it's in the bypass circuit or on the piston."

BP-51 also has good surface area and large oil volume, thanks in part to the remote reservoir, which also helps it to dissipate heat. Good heat dissipation means that the damping properties of BP-51 will not taper off in difficult and hot conditions such as when driving along severely corrugated roads or scrambling over rocky terrain for extended periods of time.

So just how much cooler does BP-51 run than a normal steel-body shock absorber? "In the early development phase we did a back-to-back with two HiLux's, one running steel-body twin-tube technology and the other a BP-51 prototype," says Stuart. "Over a series of humps that we created, we were pretty quickly up to 190 degrees on the rear of the twin-tube shocks whereas the BP-51 was barely getting to 100 degrees; it was in the 90s, so that was a significant result."

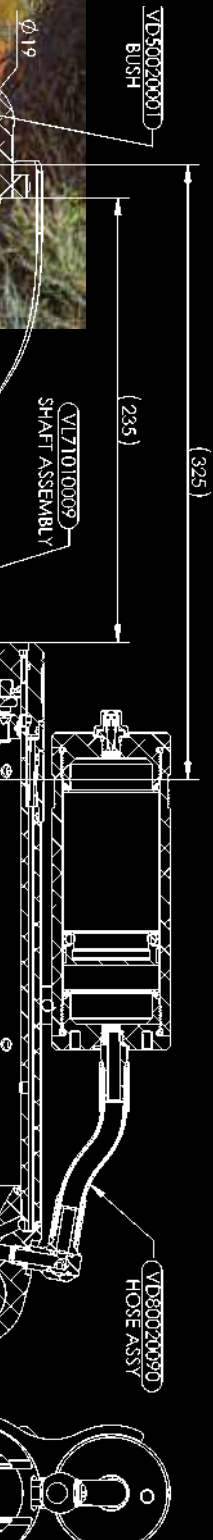



A JOB WELL DONE

BP-51 is without doubt one of the most impressive shock absorbers I've ever sampled. With its internal bypass position-sensitive technology, adjustable spring preload and independently adjustable compression and rebound damping, it has brought racing technology to everyday four wheel drivers. And the fact that it's so cleverly packaged means that it's suited to modern coil-over IFS vehicles as well as those with traditional live-axle set-ups.

Sure, it allows you to drive faster in off road conditions, but that is not the premise of BP-51. Its real benefit is its ability to provide outstanding vehicle control without compromising on ride comfort.

So what does Stuart Fooks think of the job he and his team have done?

"I'm very critical of it, because it's our project and it's our baby, but we've definitely met the objective to develop the best bolt-in aftermarket shock available... We've lived this product for the last five years, and the result is just an awesome, unparalleled suspension system. Our initial objective of trying to make the most comfortable shock at ride height, with the most control in the end zones for off road ability... has been met. And from people within the company, and outside of it who have experienced the product, they concur and endorse what we've done."



TO FIND A WAY TO OVERCOME THIS TRADE-OFF, BETWEEN RIDE COMFORT AND CONTROL, ARB GAVE ITS ENGINEERS A CLEAN SHEET OF PAPER TO DESIGN AN ALL NEW SHOCK ABSORBER.

TORTURE TESTED

ARB has gone to great lengths to ensure BP-51 not only offers unparalleled performance, but is also one of the most durable shock absorbers on the market. In fact, strength and durability testing commenced at the very beginning of the project, in the design stage.

“Testing started in the office with CAD and FEA (Finite Element Analysis) simulations,” says Stuart Fooks, “FEA simulates stresses through the components and the assembly to make sure we’re not going to have any early failures, just to give us that peace of mind before we’re prototyping things... we want to make sure that what we’re making is structurally sound before we kick it off. Then, once we’d assembled the shocks, we commenced on-vehicle testing at a number of proving grounds and racetracks. Testing locations included Baroota Track in South Australia, a lot of testing in Little Desert in Victoria – probably 10-12 trips, one or two times a week for a while there – then some outback testing on various properties, in the Simpson Desert, and at Melbourne 4x4 Training and Proving Ground in Werribee, Victoria.

“The first testing is subjective: does it work the way we expect it to work? We do a lot of ride tuning, trying to meet the initial objective of comfortable ride at ride height as well as control in the end zones of the shock travel, so that we’re not putting excess loads through the vehicle when we’re hitting bump stops, which would create an uncomfortable environment when travelling in the vehicle. “Of course, we also

have instrumentation to measure things like shock temperature, wheel speeds, shock speeds and shock travel.

“We put strain gauges on some components which measure the amount of strain that component has seen. We use that strain data to calculate the force that the vehicle is putting onto that component. Once we’ve got that basic information we then take it back to the lab environment and repeat the test under lab conditions. We can apply loads in the lab higher than what we’ve measured on the vehicle, and run it for hundreds of thousands, or even millions of cycles, depending on the component.

“For the aluminium in the body in particular, we put strain gauges on components to measure how much force was being applied to the shock absorber assembly, so we could go back to the lab, we could do the tensile test, pull the shock in half and check that it’s not the extrusion of the body that’s going to be the weakest link. We knew what loads we were seeing in the field and then we achieved a magnitude greater than that in our tensile pull.

“We also did a rig test where we set up a cycle that would continually top-out the shock; a press would come down and compress the shock, and then the press would get out of the way quick enough that the shock would then top-out. We did millions of cycles, representing years of use.”

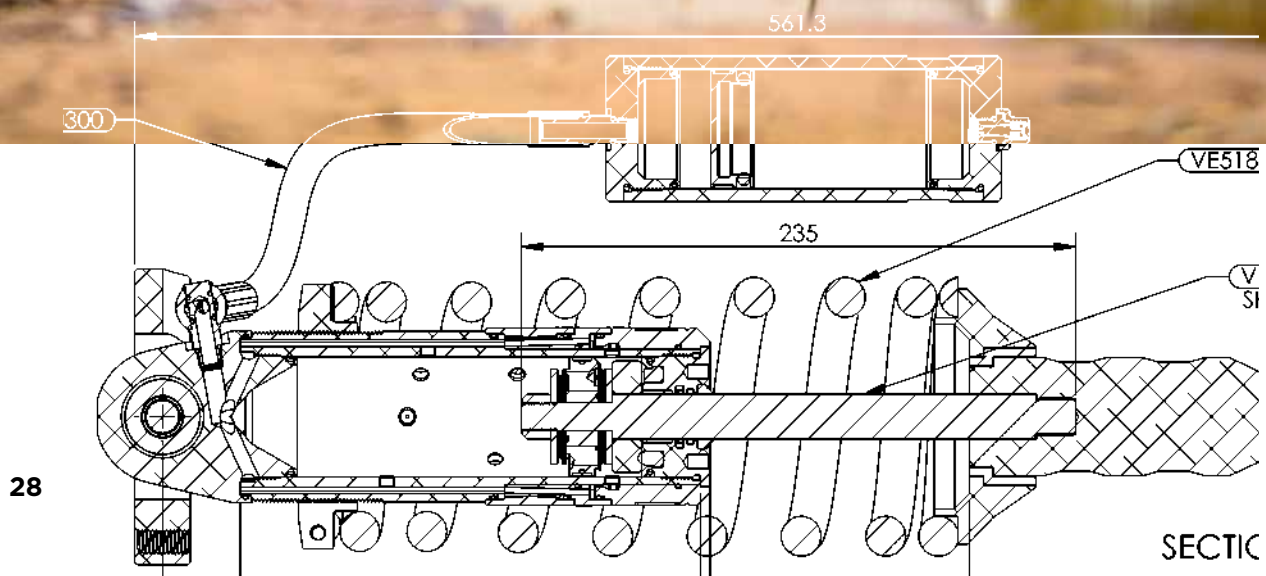

ARB HAS GONE TO GREAT LENGTHS TO ENSURE BP-51 NOT ONLY OFFERS UNPARALLELED PERFORMANCE BUT THAT IT'S ALSO ONE OF THE MOST DURABLE SHOCK ABSORBERS ON THE MARKET.



Stuart Fooks, OME Lead Engineer,
BP-51 Project.

HISTORY LESSON

OME suspension has a long history dating back almost 40 years. Greg Milton, ARB's National Product and Services Manager, has been there for much of it throughout his 27-year career at ARB.

"Old Man Emu was started by a Sydney barrister and motoring enthusiast, John Chapman, in 1976," explains Greg. "He originally had a partnership in a pioneering 4x4 equipment importer and distributor called Woods Equipment in the mid-70s but he got very interested in off road racing and renamed the company and formed the team "Old Man Emu" due to the native Emu's observed stable high-speed progress over uneven terrain.

"Apart from the racing, John started looking at the growing 4x4 market and the poor quality suspensions on the standard vehicles on offer in those days. He saw the opportunity to grow an aftermarket suspension business that could have a future. Whilst running an off road racing team, a lot was learnt about design and strength of springs and effective valving of shock absorbers and this was a sophistication the 4x4 owning public could benefit from. Over the next 10 years that product range grew to a superb array of tailored solutions for all the popular vehicles, and options to suit the variety of needs owners had and the loads they carried.

"The range was sold through a network of licenced OME fitters that covered a spectrum of outlets from ARB to some Opposite Lock and TJM outlets, as well as independents, all of whom had competent workshop mechanics to install the products properly. John himself conducted the mandatory training sessions for licenced installers and, with the application of his other talents, they were very entertaining as well as educational courses.

"John remained involved in racing and the team continued to grow, as did the business, but in 1988 he decided it was too much of a full-time job with even more potential for the future, and he was missing his old legal-oriented pursuits. He decided to sell the business.

"The first person he called was Roger Brown, the Chairman of ARB who he had come to know and respect. Roger jumped at the chance to buy the business and it has continued to expand dramatically, prosper and contribute to ARB's ongoing success as a fully Australian developed and tested suspension product range, supplied to discerning 4x4 and commercial users across the globe."

COMMON THREAD

WORDS BY
DAVID KIRBY

Think about this. If you asked a handful of people as to what material their clothing was made from, you would expectedly be met with some confused gazes. Today, colour and cut rule the buying decision, foremost above what functionality the product may provide.

Surprisingly, the garments you take travelling ultimately dictate how memorable your travels are – and with any luck, not for the wrong reasons. While this article should not be taken as *the* definitive guide, it details a selection of the more critical areas to consider, whilst not getting too heavy.

Simplistically, materials and fibres can be classified in three categories, each being sourced from animals (Wool), plants (Cotton) or created synthetically (Nylon) respectively. Man-made materials have defined entirely new categories of adventure clothing, and are allowing manufacturers to create technical clothing with limited drawbacks.

Cotton has long been the dominant staple of the textiles industry, with synthetic fabrics making headway in recent years. So much in fact, that cotton's share of the fibre market has seen a gradual but consistent decline in the past decade.

Nowadays, with the plethora of materials available, all draped in a slew of marketing hype, buying clothing is a very different experience.

The landscape has changed, and so has the advertising. Synthetic materials are commonly displayed with waterproof ratings on the garment – typically measured in millimetres. You may have noticed a jacket rated to 10,000mm of waterproofing resistance. This equates to the material being able to support a column of water pressure up to 10,000mm or 10 metres, before the liquid can penetrate the fabric. The fabric is placed into a testing rig, forming the base. The tube is then filled with water and testing commences. Naturally, the greater the number, the more waterproof the product is. Ratings range from zero to 20,000mm, with garments rated higher than 16,000mm able to survive heavy rain.

Breathability utilises a similar numbering scale, with measurements taken in grams. This measure demonstrates how many grams of water vapour can pass through one square metre of the fabric in a 24 hour period. Again, the greater the number, the more the fabric will breathe and provide cooling to the skin and body.

It may come as a surprise to most that not all performance outerwear is completely waterproof. Doing so would render the garment with zero breathability (a raincoat for example). I'm sure most of you could relate to feeling hot and sweaty at some point while wearing one.

Waterproofing and breathability are independent to each other, so finding the right equipment requires a trade-off in one area. Granted, the current generation of fabrics have improved in these respects markedly, but if you are looking for the perfect product then prepare to be disappointed.

With the technical discussion surrounding synthetic materials behind us, you can begin to understand the importance of selecting the right item for your trip. Whilst cotton provides a great deal of comfort and breathability, it is highly absorbent and will quickly soak up sweat. Feeling damp is never high on the list, although in certain situations it can be far more problematic. Falling into cold water and remaining clothed quickly draws body heat away, and can even result in hypothermia. Further to this, cotton is one of the slowest fabrics to dry, and does not 'wick' away moisture. Animal fibres such as wool provide good wicking properties, but like cotton, are disadvantaged by their absorbency and lengthy dry times. To overcome these shortfalls, manufacturers are increasingly turning to blends, such as poly/cotton, to achieve products with all round performance.

Wicking you ask? It is a term to describe any material that draws moisture away from the skin and makes it readily available for evaporation. Synthetic materials are excellent in this regard, due to their inability to absorb perspiration. The composition and weave of the material permits water to pass directly through (wick), with the end result being a product that is designed to keep the wearer dry during strenuous activity. A word of caution – synthetic clothing is highly flammable and will melt easily. If you are planning on having a campfire, keep your distance.

Understanding the significant traits of particular fabrics will put you in good stead when purchasing clothing for the back country... or even the backyard. Go in-store and browse the aisles. Read reviews about brands and their offerings. Know the climate in which you'll be travelling, and tie it together with a little pre-trip preparation.

Great Australian Bight

ACROSS THE BIGHT

BIGHT



**MILES OF SAND, PRECARIOUS
CLIFF EDGES AND RACING
THE TIDE. RON AND VIV MOON
TAKE US ON AN ADVENTURE
FROM SCENIC ISRAELITE BAY,
WA TO THE REMOTE FISHING
VILLAGE OF BAIRD BAY, SA.**

WORDS AND PHOTOGRAPHY BY RON AND VIV MOON

The going quickly and suddenly changed. One minute we were driving on hard packed sand, the very next second we were bogging down, the tyres cracking through the thin covering of white sand into an unknown depth of soft, claspings, wet and rotten seaweed.

I slapped the gear lever back into second and floored the accelerator of the 4.2L Patrol, the growl from under the bonnet letting me know that the engine was working hard in its bid to get us to safer ground.

Earlier that day we had left Israelite Bay on the remote southern coast of WA. Edward John Eyre had originally traversed this coast in 1841 and he had passed this spot on his epic trek from east to west. Failing to name the bay it was left to the Dempster brothers, white pioneers of the district, who in their travels in 1863, noticed that the area around the bay seemed to be the boundary between Aboriginal tribes who did and did not practice circumcision. Think the bible, the Israelites and you get the connection!

The bay then became the important site of its historic telegraph station that operated there from 1877 to 1927 and helped link Perth, via the Overland Telegraph Line (OTL), with the eastern states. The station was originally built from timber and then replaced by a stone and iron structure in 1896, while nearby is 'Glencoe', a small stone cottage built in 1883. Built around the same time as the grand new telegraph station was a timber jetty to help load the increasing volume of wool that was being produced from the sheep properties in and around the bay. Two small cemeteries also date from those pioneer times and can be seen in the area.

These days Israelite Bay and the surrounding coast is protected in a number of nature reserves and is best known for its great fishing where it also attracts keen four wheelers and campers wanting to get away from it all.

As our day wore on, we were forced off the beach a couple of times by the weed banks and soft sand and then we followed a track that parallels the beach and ducks between samphire covered

flats and occasionally across dry shallow, billiard-table flat lake beds. This track was initially established for the crews maintaining the old OTL and occasionally we came across a forlorn wooden pole or a single strand of wire that was once the only regular connection between the west and east coasts of Australia.

Close to where the Wylie Scarp (named after Eyre's faithful Aboriginal companion) meets the sea, just west of Point Culver, the Bilbunya Dunes crowd up to the near sheer escarpment. The prevailing southerly winds have built these white masses of sand into some of the tallest dunes in Australia, their peaks sitting atop long, sinuous, almost sensuous, ridges of steep-sided sand. They were mind blowing and we couldn't drive past. We wound our way in from the beach along a low gap in the dunes and camped just a few hundred metres back from the beach at the base of these wind blown mountains. They were mightily impressive!

Next morning, with the early morning sun colouring these great sand mountains, we dodged our way amongst tall dunes and then through scrub to find our way up the scarp. Rubber belting has now been laid down on the steep soft climb to assist vehicles climbing the scarp and in fact, makes the whole deal quite a walk in the park. The view from the top of the cliffs is beautiful with a strip of white sand and

turquoise water rimmed by a dark blue ocean stretching away far to the south.

For the next day we were subjected to the slow torture of the cliff tops. The narrow and rough limestone studded track wound incessantly amongst the thick mallee and tea-tree scrub and it was slow going, where a stake or puncture from a carelessly placed tyre was always on the cards.

Near the miniscule Toolina Cove, with its patch of sand tucked in amongst the high walls of the Baxter Cliffs (named after Eyre's companion who was killed near here) we stopped to camp for the night.

The Baxter Cliffs stretch for another 110km east to Twilight Cove, named after an 1867 shipwreck, and from near the cove big dunes bound away for over 130km to the east forming the Nullarbor's largest dune system. The Eyre Sand Patch as it is known, where Edward John Eyre had found life saving water in his epic trek across the Bight, became the site of the Eyre telegraph station, which is now the Eyre Bird Observatory and lies just 25km east of Twilight Cove. A few years ago we had entered the big dunes from the beach near the old station and pushed west. Now, we pushed along the cliffs and then through densely covered dunes to Twilight Cove, before risking a run along the high tide narrow beach to the historic site of Eyre.

WE PUSHED ALONG
THE CLIFFS AND THEN
THROUGH DENSELY
COVERED DUNES
TO TWILIGHT COVE,
BEFORE RISKING A
RUN ALONG THE HIGH
TIDE NARROW BEACH
TO THE HISTORIC SITE
OF EYRE.



(Left) Sunrise at
Fowlers Bay.
(Right) Disused cable
from OTL marks the
route for much of the
way.



Three days later after a short drive along the fantastic beach at Eucla and exploring the local area we were again heading through large, dense thickets of mallee as we met up with the longest fence in Australia. Here in the heart of the Wahgunyah Conservation Reserve in SA, the Dog Proof Fence that stretches for thousands of kilometres across outback Australia makes its final run to the sea ... and the cliffs of the Great Australian Bight.

That evening we camped amongst some dunes east of Dog Fence Beach where a rocky headland jutted out into the wind swept sea. East from our vantage point amongst the high set dunes, a long sweep of beach stretched away eastwards into the sea mist.

Over the next couple of days as we pushed east we went from the Ocock Sandhills to the vast expanse of the Wahgunyah Sandhills and then into the Chalgonippi Sandhills, the names a separate identity on the map, but in reality a continuous mass of white peaks paralleling the coast with the dune fields varying in width from 100 metres to over a kilometre.

At one point we wound our way back to the beach to find what remained of Wahgunyah Well, which is located on a largish flat amongst the dunes and just up from the high tide mark. The well has long silted over but it was in a place like this that Eyre and his companions had dug deep for and had found water amongst these very dunes. Still, whether it was this same spot, is hard to tell.

At another spot we skirted along the edge of the cliff, our vehicle's wheels just a metre or so from the sheer drop, the camber of the track tilting us alarmingly towards the ocean far below. Luckily the scrub covered dunes that had pushed the track and our small group of adventurers right up to the edge of these tall sea cliffs quickly released their grip and our party could move back from the edge a little and breathe a lot more easily!

Later that same day after more beach driving and cliff crawling we headed across the limestone studded flats to the crest of Scott Point. Named by Eyre



WE SKIRTED ALONG THE
EDGE OF THE CLIFF, OUR
VEHICLE'S WHEELS JUST
A METRE OR SO FROM
THE SHEER DROP, THE
CAMBER OF THE TRACK
TILTING US ALARMINGLY
TOWARDS THE OCEAN
FAR BELOW.

██████████

after one of his faithful companions, the tall headland is crowned with a cairn of stones that give an impressive view of the coast. From there we found our way onto Scott Beach for the long drive around the sweep of sand that like most started off firm at one end and was soft and boggy in the apex of the arc, where a couple of our group bogged down and a quick snatch strap recovery was called for. Then the sand firmed again as we headed for the easternmost headland and an exit from the beach into low dunes that we drove amongst to come out on yet another beach that led to the small hamlet of Fowlers Bay. Eyre had found water here behind the beach in 1841 and set up a base camp and the protected spot became the start (or finishing) point for other explorers including De Lisser (1865) Forrest (1870), Giles (1873 & 75) and Tietkens (1879) just to name a few.



Our four wheel drive adventure was nearly over as we bypassed a long series of beaches and headlands and headed to Baird Bay, just south of the more well known Streaky Bay, where we had an appointment with the delightful Australian sea lions that congregate here. There is no better place in Australia to interact with a group of friendly, playful seals than this place; it's safe and you don't have to be a strong swimmer as the shallow water allows you to stand up much of the time, while the seals will come right up to you. Their friendly attitude and captivating antics win even the hardest sceptic over and you are soon trying to keep up with them as they dive and cavort around you. It was a fitting end to our latest trip along this wild, little visited coast!

Travel Planner

The southern coast of Australia is pretty poorly covered as far as decent mapping is concerned. Your best bet is 1:250,000 topographic maps.

Ron & Viv Moon's guidebook, *Across the Bight & Nullarbor*, is the best guide to the region. Available at good map shops and 4WD stores you can also get it via the web at: www.guidebooks.com.au.

Diving with the seals at Baird Bay has to be one of the great wildlife experiences available in the world today! For more details contact Alan and Trish Payne, ph: (08) 8626 5017, or www.bairdbay.com

For more info, check out: www.visitesperance.com, or: www.nullarbornet.com.au



RAISES THEE

ARB'S NEXT GENERATION SUMMIT
AND ALLOY BARS REDEFINES
FRONTAL PROTECTION... AGAIN.

SINIG BAR



ALMOST 40 YEARS AGO TO THE DAY, ANTHONY RONALD BROWN CREATED THE FIRST EVER ARB BULL BAR.

Working from his home garage, no one could have predicted how significant that project was, nor the 4WD accessories movement he had set into motion. Within weeks of taking his Series I Land Rover on an off road holiday to Cape York, Anthony had begun gathering a following of interested 4WDers, eager for a product that, until then, was virtually unattainable. Word quickly spread and within the year, manufacturing moved to a 93m² factory in Ringwood, Victoria, Australia.

Fast forward 40 years and ARB has grown to be an internationally acclaimed brand with over 1,300 employees - an industry leader in all things 4WDing. Over that time the ARB bull bar has followed a path of continual improvement and innovation, with teams of engineers dedicating years to research and development, in order to ensure ARB remains the preeminent manufacturer in the industry.

Constant evolution of the ARB bull bar has resulted in many industry firsts and ARB has continually proven itself to be the industry leader when it comes to development, design and innovation.

Continuing this legacy, ARB is proud to release an all new range of ARB bars. Included in the range is the ARB Summit bar, a new steel bull bar, redesigned from the ground up to provide a bolder presence and a higher level of detail for today's range of larger, more sophisticated 4WDs. Joining the new steel bar, and sharing many of its key design features, is ARB's first Alloy bar (more on page 44).



SUMMIT BAR

Design & Development

Recognising a shift in modern vehicle design, moving towards a greater level of refinement, detail and on road presence, ARB decided to task its engineering and product management team with revolutionising the current design. Always looking to improve its product range, the engineering team began a long process of research and development to truly understand the customers' needs and wants. Paying close attention to the unique styling differences emerging from each manufacturer, the project's foremost objective was to ensure the bull bar complemented the vehicle whilst still providing the unparalleled level of frontal protection for which ARB's bars are renowned.

By utilising alternative manufacturing processes such as press forming (see page 43), and incorporating a range of new and practical features, the ARB development team has created a bar with a bold, modern look and a level of finish above all others.

Protection

The adventurous nature of 4WDing inevitably increases the risk of vehicle damage when off road. A good quality, well engineered bull bar provides substantially improved protection for vulnerable mechanical components against animal strikes and other off road obstacles - a particularly important consideration when travelling in rural and remote areas. The Summit bar's vehicle specific design, ensures integration with original equipment components, resulting in maximum functionality and strength.

The Summit bar incorporates a durable steel construction and ARB's acclaimed multi-fold upswept and tapered wing design for optimum strength and approach angle. Superbly engineered, the bar is air bag compatible with a mounting system that secures to the chassis via high tensile bolts and hardware. The Summit bar also incorporates under bar protection panels on the centre and either side of the bar to ward off water, stones and other road debris. Twin Hi-Lift jack points have been cleverly located below each buffer for optimum strength and reliability, as well as preventing the Hi-Lift jack from interfering with the buffer.



Styling

The Summit bar is specifically designed to complement the unique contours of individual vehicle models. This ensures the best possible fit, look and functionality for a particular vehicle. To achieve this, a number of new styling features have been incorporated into the bar's appearance to complement the contemporary look and greater on road presence of today's modern 4WDs.

Updating from the standard laser cut upright cover straps, ARB engineers have developed a new press formed design, some 50% wider, to suit the new bar. To further refine the cover strap design and provide greater aesthetic appeal, intersection mouldings have been developed to better integrate the cover straps with the top of the buffer.

Another area of focus for ARB's engineers was the intersection of the larger 60.3mm outer frame with the increased radius on the leading edge of the wings. Rather than passing through the top of the wing, the Summit bar's astute design passes through the wing radius, utilising pulse welding for a visually appealing finish.

Exclusive to the Summit bar are newly designed two-piece buffers, a centre pan grille and the recently released, updated fog light and surround. These three components have been specifically engineered to integrate seamlessly with each other and the overall bar design.

The updated split pan design has been widened and includes a two piece grille to give the bar a crisp, factory appearance

while providing greater air flow to the radiator. The clever two-piece grille also incorporates a hinged opening to allow access to the winch clutch handle. This access panel is easily opened and closed, and provides a solution to the often restricted clutch lever access when larger lights are fitted.

A standard feature in the new Summit bar, ARB's unique LED clearance/turn signal lights are neatly installed within press formed apertures in each wing. Likewise, ARB's new fog light surrounds have also been incorporated into the Summit bar with fog lights available as an optional extra. Available as standard in a natural black finish, with optional colour coding available for owners looking for greater aesthetic appeal.

To add additional versatility to the Summit bar's design, the ability to fit a number of popular winch models was also a key consideration. Unlike traditional bars, where the winch control box is fitted on top of the centre pan, the Summit bar features a clever integrated control box mount, to position the control box lower in the pan. The control box mount has a variety of mounting holes to cater for a number of winches, including selected Warn, Smittybilt and Bushranger models.

Like the new cover straps, press form technology has also been used to create a stronger and more visually appealing top pan, and, continuing the high level of detail built into each Summit bar, an aluminium, 4mm press formed winch cover panel has been developed to cater for customers who don't have a requirement for a winch. This panel is recessed into the top pan to provide a more integrated appearance.

Laser cut holes have been included in the top of the pressed centre pan to provide easy fitment of a range of compatible driving lights, including the ARB Intensity LED range as well as IPF 808, 800 and 900 series lights. Two aerial mounts are welded to the centre cross tube for fitment of a UHF/AM radio or mobile phone aerials.

Like the majority of ARB bull bars, the Summit bar comes standard in a hard wearing, zinc rich primed black powder coat finish, with the option to colour code to your vehicle.

The new steel Summit bar will be available for the Ford Ranger T6 PX 2011 on from March 2015 with more models becoming available throughout the year.

Contact ARB for part numbers and pricing.





(Clockwise from top left) Integrated control box mount, two piece buffers and fog light surrounds seamlessly integrate with each other, two piece grill opening for access to winch clutch handle.

Press forming process

Like the rest of the ARB bar range, Summit bars start their life as a flat sheet of steel. However, unlike traditional bull bar manufacturing, once the components are laser cut, they're placed into a press tool where the finished shape is formed under more than 400 tonnes of pressure. This process results in a more three dimensional shape, with the ability to produce larger radiuses than would otherwise be possible. It also provides much greater overall strength, while retaining the exceptional level of accuracy for which ARB is known for. To ensure ultimate consistency and produce a precise finish every time, ARB has invested heavily into bar specific tooling for the new Summit range.

Side Rails & Steps

With the redesign of the Summit bar, a new clamping system was required to attach the front rail to the now larger outer frame of the bar. Rather than simply introducing a larger side rail clamp, the ARB engineering team developed a complete clamp redesign, providing a great number of advantages over the standard rail clamp including more accurate fitment.

The steps consist of an anodised silver extrusion, featuring front to rear ridges for added grip. Both side rails and steps are manufactured from durable steel construction for maximum protection and are finished in a zinc rich primed black powder coat as standard, with the option to colour code if required.

ALLOY BAR

As the leading manufacturer of steel bars in the industry, ARB's main focus has always been to ensure that the high standard of development and engineering for which we are renowned, is maintained.

Further to that, ARB is also continually looking to satisfy our consumers' needs and wants. More recently, we've found that these needs and wants increasingly include the desire for a wider selection of options when it comes to design and materials.

To satisfy this growing category of consumers, and following an extensive process of development, engineering and testing, ARB is proud to introduce our very first aluminium bar, the ARB Alloy bull bar.

Not willing to entrust the production of an all new ARB bull bar to a third party manufacturer, ARB has invested heavily in new resources and equipment in order to expand its manufacturing capabilities and subsequently ensure that the new Alloy bull bar is worthy of the trusted ARB badge.

Developing an alloy bull bar was not a foreign concept for ARB, having already carved out a long history working with alloy products, including our popular range of alloy roof racks and nudge bars, not to mention alloy bull bars for some of Australia's largest OE manufacturers.

Having this solid grounding in aluminium manufacturing, along with industry leading expertise in bull bar design, the ARB engineering team was exceptionally well placed to deliver an alloy bar that was not only lightweight and extremely strong, but also one that complemented the modern styling of today's 4WDs.

Devoting countless hours to the concept and styling, using CAD, rapid prototyping, Finite Element Analysis (FEA) and air bag compliance testing, the engineering team has developed an all new style of bar, distinctly different from ARB's current steel range.

Like steel, alloy is available in a number of specifications and resultant strengths. Three different alloys and tempers are used in the production of the ARB Alloy bull bar, each specifically chosen to provide optimum



corrosion resistance and high fatigue strength. Critical to quality aluminium construction, careful attention to detail has been paid to the welds, with all visual welds being produced through a combination of CMT and TIG welding.

The new Alloy bull bar has been specifically developed to suit each individual vehicle make and model to ensure optimum fitment and styling. Features such as ARB's newly designed two piece buffers, centre pan grille, fog lights and fog light surrounds all integrate seamlessly with each other, and the rest of the bar, to deliver a product that looks at one with the vehicle.

Similar to ARB's new steel Summit bar, the split pan design has been widened to assist with valuable airflow and features a two piece grille with a right side opening for access to the winch clutch handle. The Alloy bar also features ARB's new LED clearance/indicator lights, mounted within a press formed aperture in each wing.

An optional winch mount, that sits lower in the pan, directs the full weight of the winch and control box to the bull bar mounts, rather than the bar assembly itself. For owners that do not require a winch, the seamless appearance of the new Alloy bull bar is maintained with a 4mm aluminium pressed formed cover panel.

For additional accessory fitment, the Alloy bull bar also features laser cut holes to mount a range of compatible driving lights, while two aerial mounts are located on the rear of the centre tube.

The new ARB Alloy bull bar will be available for the 2013 on Toyota Prado GX & GXL models from June 2015, with more models becoming available throughout the year.

Contact ARB for part numbers and pricing.

(Clockwise from top left) Integrated control box mount and wider split pan design. Fog light surrounds and LED clearance/indicator lights integrate with the Alloy bar's two piece buffers. Designed to mount a range of compatible driving lights and aerials, The Alloy bar is specifically designed to suit the styling of each vehicle.





ADVENTURE AUSTRALIA TREKS & TOURS



Outback Australia has so much to offer and this team of adventurers will make your next holiday vision become a reality with a range of experiences not to be missed. Adventure Australia Treks & Tours operate in the premium end of the adventure 4WD market, offering a fully customisable touring service. Providing an outback adventure like no other, the tours are carefully planned with a long list of stops to some of the most mind-blowing sites Australia has to offer from a viewpoint that many don't get the opportunity to experience.

A small team of dedicated staff with a strong passion for the great outdoors run the tours. Their knowledge and love for adventure give guests the opportunity to get a taste of what outback Australia is all about. There is spectacular scenery waiting to be discovered including breathtaking waterfalls, pristine lakes and rivers, untouched bushland and rainforests, awe-inspiring rock formations, aboriginal art and an abundance of native Australian wildlife. With tours operating in North Queensland, the Northern Territory, Central Australia, Uluru, WA, Tasmania and SA there is something for everyone!

Adventure Australia Treks & Tours offer a very exciting and very exclusive location on their list of tours. Fraser Island – home to some of the most idyllic beaches in the world. Over the years, this island has grown to become a must see destination for 4WDers around the country. With enthralling scenery, incredible coastlines and almost perfect weather, it's easy to see why. Being the only commercial tourism operator permitted north of Orchid Beach, the team at Adventure Australia offer an adventure that is a must for any 4WD enthusiast.

Adventure Australia offers a range of guided and unguided tours for individuals, couples and small groups. Tours and itineraries can even be customised to suit every individual's needs. Simply express to the team your ideal location, your budget and time frame and they will do the rest. With a range of accommodation including high quality hotels, motels, camps sites and lodges there is something to suit every adventure. All meals, transfers and accommodation are included in the tour prices – all you need is a little extra money for optional snacks and activities. The team at Adventure Australia really have thought of everything!

There are three main driving options for these tours. If you feel like taking control of the wheel and driving then the 'Tag Along Self Drive Tour' is a great option. Guests can drive themselves in one of the fully equipped LandCruiser 4WD's throughout spectacular scenery. Or bring your own 4WD if you'd prefer. Being part of this tour you can be rest assured that if you get into trouble one of the highly experienced tour guides will be there to assist. If you are an experienced 4WDer but don't own a 4WD the 'Independent Tour' is perfect. Hire one of the premium adventure 4WD Land Cruisers to take on your next



for touring is paramount, and Martin has spared no expense ensuring that his customers are adequately prepared for the many number of tours run by Adventure Australia.

If you feel like exploring the Australian outback on an off road adventure, or want a holiday experience like no other, Adventure Australia have the perfect tour for you. The possibilities are endless and with so much to discover there is no better time to start an exciting new quest than now. So, what are you waiting for? www.aatt.com.au



off road journey. The third option is to join a 'Guide Driven Tour' where you will be allocated a tour guide who will drive you in a luxurious and comfortable LandCruiser 4WD. This is a good option if you don't quite feel up to driving or would prefer to just sit back and enjoy the ride. All of the touring convoys have no more than four vehicles so guests can mingle in an intimate group with like-minded 4WD adventurers.

The fleet of 4WD's used on the tours are the best in the business, and are specially equipped to provide comfort, safety and accessibility to even the harshest of off road tracks. Director Martin Josselyn is excited to offer his tour vehicles ready to go, and says "vehicles are available with all the gear needed for an Australian adventure. They have everything from a satellite phone to a kitchen sink." He lives by the company motto of 'extraordinary tours for extraordinary people to extraordinary places' and has utilised his off road knowledge to build the brand. The fleet of Toyota 79 series vehicles come loaded with a host of ARB gear, including a Deluxe bull bar, side rails and steps, Old Man Emu suspension upgrade, roof rack, awning, Intensity LED driving lights and loads more. Having the right equipment

Adventure Australia's vehicles are fitted with only the best equipment in the business to ensure the upmost safety and comfort for all their guests. Included in these builds is a long list of ARB gear:

- ARB Deluxe bull bar
- ARB side rails and steps
- Old Man Emu Suspension Upgrade
- Warn XDC winch
- ARB Intensity lights
- Safari Snorkel
- ARB cab rack
- ARB touring awning
- Long Ranger 180L fuel tank
- ARB recovery point
- ARB compressor with external point
- ARB RK9 recovery kit
- Hi-Lift Jack
- ARB 78L Fridge Freezer
- ARB reversing safety camera

KAK ADU DREA MING

Words by Dean Mellor
Photography by Offroad Images



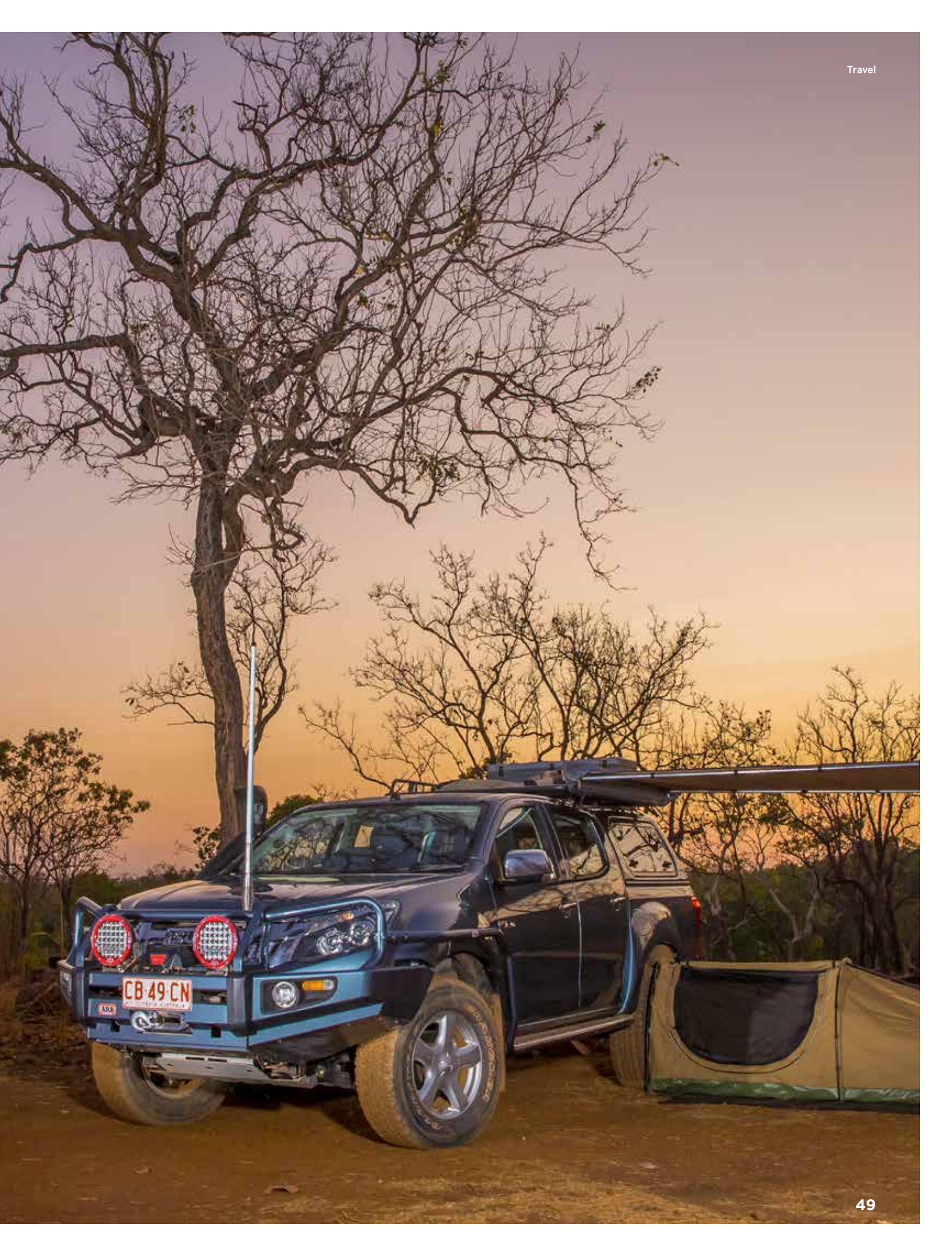

IMAGINE A WORLD HERITAGE LISTED LAND OF AMAZING NATURAL BEAUTY THAT'S HOME TO A VAST ARRAY OF WILDLIFE AND IS A LIVING CULTURAL LANDSCAPE, BUT WHERE YOU NEED A WELL-EQUIPPED 4WD TO SEE ITS HIGHLIGHTS. WELCOME TO KAKADU NATIONAL PARK.



As is often the case with a big adventure, things don't always go to plan... and so it was with our weeklong adventure in the Northern Territory's Top End.

We'd given ourselves every opportunity to make things run like clockwork, arriving in Darwin a day-and-a-half prior to our planned departure to sort out gear and source supplies, but a last-minute court appearance would mean that one member of our troop wouldn't be ready for our early Monday morning departure.

We'd used that day-and-a-half wisely, picking up the two vehicles for the trip – a Toyota HiLux and a brand-spanking new Isuzu D-Max – at ARB Darwin as soon as we'd touched down in the NT's capital on a warm Saturday afternoon. Photographer Michael Ellem and I then made our way to our digs on Darwin's Esplanade where we would meet up with two of our travelling companions from our previous NT

adventure in the Red Centre – Kim and Geoff Dawes – along with Tourism NT Marketing Executive Sara Jentsch, who would also join us on tour.

We would use Sunday to source supplies for our trip, sort out all of our gear and pack the vehicles. With three occupants in each of the dual-cabs, we'd have to pack thoughtfully to ensure those in the rear seats wouldn't be squashed with a heap of gear, particularly in the HiLux which has much less rear-seat space than the D-Max. After all, we had one week to cover around 1,500km, predominantly on gravel roads and four wheel drive tracks, through both Kakadu and Litchfield national parks.

As for our sixth party member, the one with the impending court appearance, no, he hadn't gotten himself into trouble on Darwin's notoriously lively Mitchell Street the prior Saturday night. In fact, Mitchell Street is his beat, and Chris Humphries

AS WE SOAKED IN THE COOL INFINITY POOL,
WE TOOK IN THE SPECTACULAR VIEWS OVER THE
SOUTH ALLIGATOR RIVER VALLEY BEFORE US.



(Left) Our fully loaded
ISUZU D-Max.

(Right) Gunlorm plunge
pool, Gunlorm.

was needed in court in his capacity as an arresting officer. Fortunately he managed to escape court reasonably quickly and, in turn, we managed to escape Darwin's sprawling suburbs by mid-morning after fuelling up the vehicles on our way out of town.

Our destination was the Bowali Visitor Centre at Jabiru where we would meet park rangers for a media briefing before starting our exploration of Australia's largest terrestrial national park – Kakadu National Park, which covers almost 20,000 square kilometres. Bowali is also where you can buy a \$25 park pass, which allows you to explore Kakadu NP for up to 14 days (see page 56, Park Pass).

Darwin to Jabiru is a leisurely 250km drive on sealed roads, first along the Stuart Highway and then the Arnhem Highway, but we weren't interested in blacktop, so we peeled off at about the halfway point on to Old Jim Jim Road. Knowing we'd be predominantly

on gravel roads and off road tracks for the rest of the week. We dropped tyre pressures down to 28psi to aid traction and help soak up the inevitable corrugations we would face over the next few days.

For the first 30km or so, Old Jim Jim Road heads southeast through the army's Mount Bunday Training Area before it enters Kakadu NP. Like most unsealed roads in this part of the Territory, it's subject to seasonal closures, but we were here late in the dry season and the atmosphere was thick with smoke from several fires in the area, with the threat of heavy rains still several weeks away.

As we approached the ford at South Alligator River we saw our turn-off to the left. Rather than cross the ford and follow the main road directly to Jim Jim Billabong, we would head northeast along the four wheel drive track that follows the river. There are a couple of spectacular billabongs along this route and

IT WAS EERILY QUIET AS WE CREPT DOWN TO THE WATER'S EDGE BEFORE SUNRISE BUT AS A GENTLE PURPLE HUE BEGAN TO DEFINE THE EASTERN HORIZON THE BILLABONG STARTED TO COME TO LIFE WITH THE SOUNDS OF BIRDS, FISH AND AMPHIBIANS.

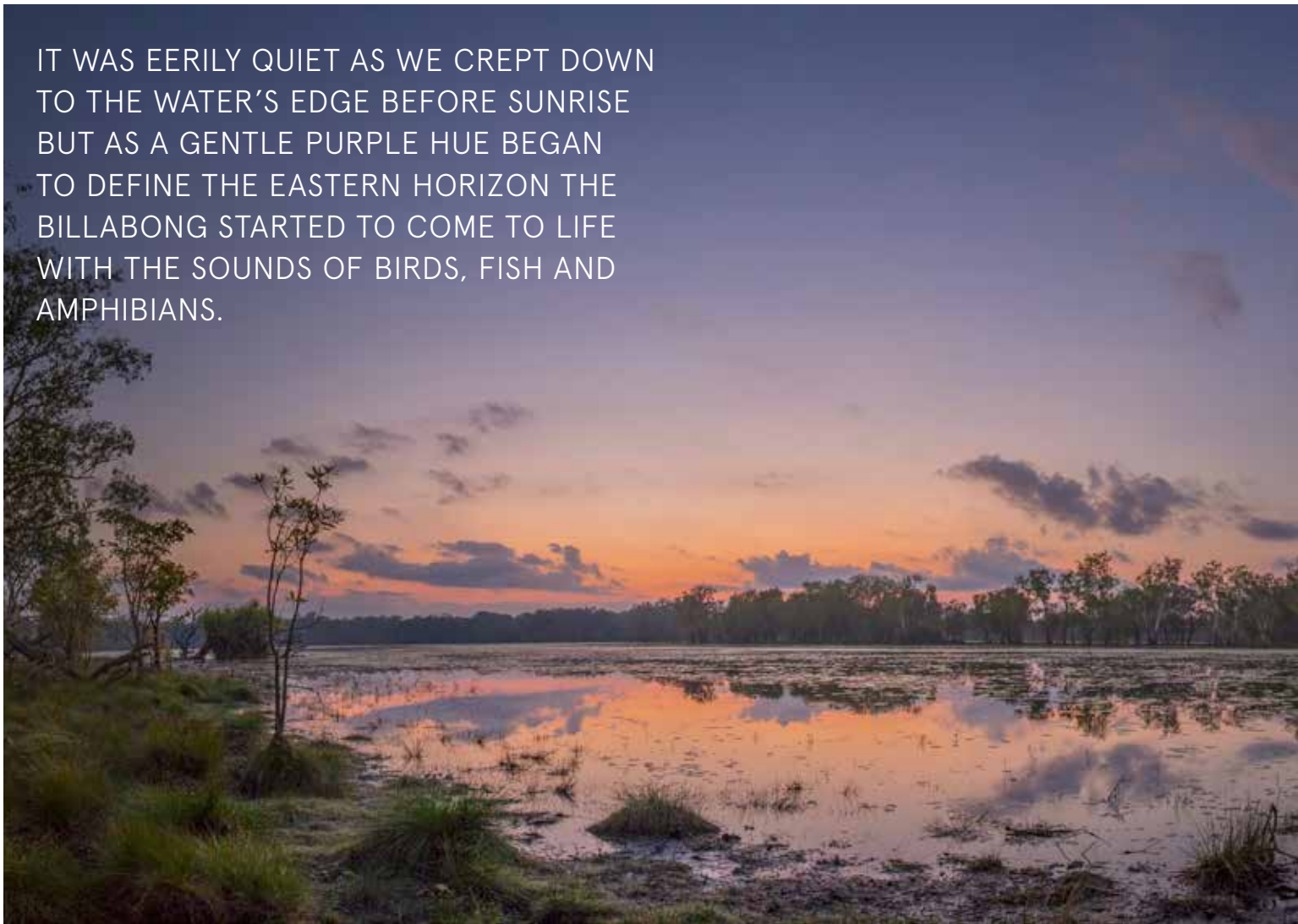

we stopped at Alligator Billabong (Gurdurunguranjdju) for a late lunch; it was already 2.30pm. While tasty wraps were prepared, Chris and Geoff wandered off with telescopic rod in hand in the hope of hooking a barramundi, and Michael marched in the other direction with camera in hand in the hope of spotting a crocodile.

A honk on the horn was enough to entice Chris and Geoff back for a feed (sans barra) but there was no sign of Michael. After wolfing down some food we spent 20 minutes or so looking for him on foot, without success, so we packed up and started driving back along the track. We eventually found him on the track near the billabong, where he'd spotted a couple of salties near the shore before they hurriedly disappeared beneath the water. It was quite amazing just how far he'd walked in such a short time; one of the advantages of long legs and a hunger to photograph as much as possible in this spectacular place.

As we continued north, back towards the Arnhem Highway, the track narrowed and became quite

sandy in sections. We may have been running late but we couldn't resist the temptation to stop off for a look around Red Lily Billabong (Djunda). Late in the dry season birdlife is drawn to Kakadu's billabongs and just some of the species we saw meandering around the water's edge here – and earlier at Alligator Billabong – included brolgas, jabirus and egrets, while white-bellied sea eagles soared overhead.

We were now on a mission to get to Bowali before the rangers shut shop for the day, so we pressed on and were soon back on the Arnhem Highway. As we approached Jabiru we calculated we'd have enough fuel for the next couple of days (the HiLux had a long-range fuel tank, but the brand new D-Max was yet to be fitted with one) so we went straight to the visitor centre.

If you're on your first visit to Kakadu, a stop at Bowali is a good place to start. The park rangers are very knowledgeable and the centre has videos, displays and a library to help you plan your visit. There's also a café and a gallery with aboriginal arts, crafts and gifts. Our media briefing took around an hour or so,



(Left) Sandy Billabong.
(Right) Jim Jim Falls.

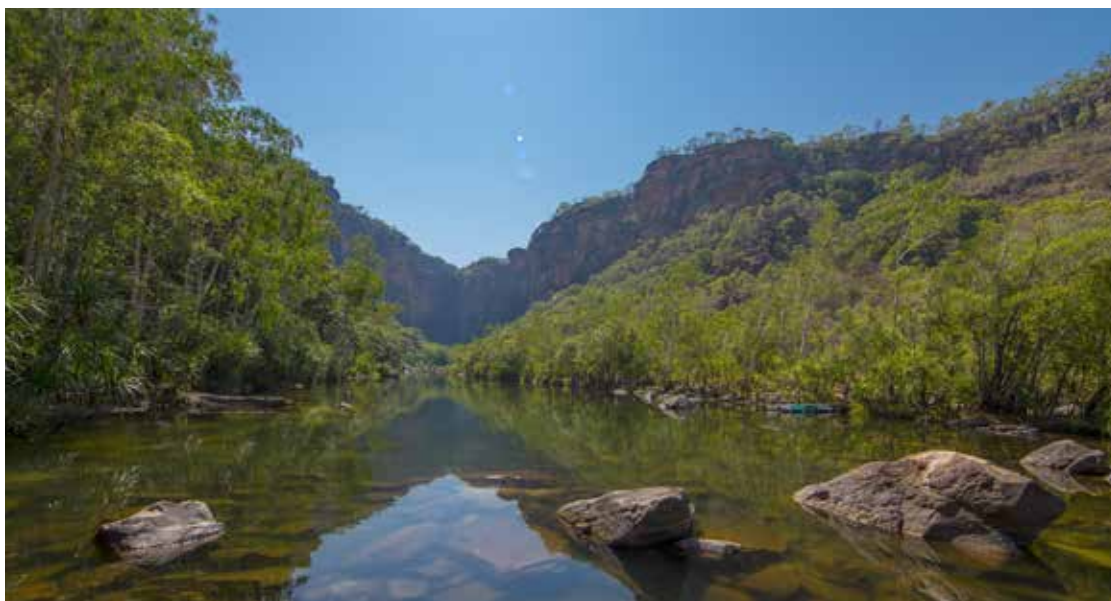

then we were on our way to our first night's campsite at Sandy Billabong, which we reached just before nightfall, giving us time to set up the campfire, roll out the swags and have a look-see down by the water before the sun dropped below the horizon.

I can't recall if it was the sight of the billabong at dusk that first took my breath away or the sound of all the birds flying overhead, seemingly frantic in their quest to make their way to somewhere to rest before nightfall. There was also plenty of noise coming from the water, with fish surfacing for a feed on the countless insects, and frogs croaking unseen near the water's edge... and, no doubt, saltwater crocodiles lurking just beneath the surface, monitoring our every movement. We calculated precisely when and where the sun would rise in the morning and deducted that this would be the perfect spot to witness it... while relaxing in a camp chair with coffee in hand, of course.

Steak and salad was on the menu that night, followed by a few drinks and an animated conversation about our latest NT adventure; to say we were all ecstatic to be here would be a huge understatement. Alarms were set and we retired to our swags at a reasonable hour, knowing that we had an early start and a big day ahead of us.

It was eerily quiet as we crept down to the water's edge before sunrise but as a gentle purple hue began to define the eastern horizon the billabong started to come to life with the sounds of birds, fish and amphibians. We spent a good couple of hours here taking in the sounds and enjoying the changing view across the billabong as the sun popped through the clouds and lit the spectacular scene before us. After brekky we drove back out to the Kakadu Highway and only a few kms up the road we were

once again on a 4WD-only gravel road, this time heading to Jim Jim Falls. The road is nice and wide for most of its 60km, but the last stretch to the car parking area at Jim Jim Falls is a narrow and winding track, with a sandy base and rocks laid down where finding traction could otherwise be an issue. Despite having to navigate this tight track through the trees, while keeping an eye out for oncoming vehicles, I couldn't help but appreciate the impressive rock formations that make up the escarpment here, their ochre glow contrasting with the green trees that seem to poke out from seemingly random nooks and crannies.

It was a warm day and the mercury was nudging the mid 30s by the time we started the rocky 900m walk from the carpark to the falls area. Although there's no climbing involved, there's plenty of clambering; you have to conquer various-size boulders to reach the plunge pool at the end of the track. Fortunately, much of the walk is shaded as you work your way through monsoon forest. While water doesn't flow over the 150m escarpment in the dry season, Jim Jim Falls is still an impressive sight, with its towering rock face and deep, enticing water below. Ironically, the falls here only flow in the wet season when the access road is closed, so the only way to witness this spectacular event is from the air.

While some swim at Jim Jim Falls plunge pool in the dry season, it can still be a risky business. Parks Australia warns that visitors who choose to swim here do so at their own risk as there's never an ironclad guarantee that estuarine crocodiles aren't present... and swimming below the plunge pool is an absolute no-no.

For those with any energy left, there's a very steep, marked walking track (Barrk Malam walk) that leads



to the plateau above the falls. It's said to take around four to six hours and is only suitable for very fit walkers. Our excuse? We still had to explore Twin Falls, so we skipped the walk to the plateau and made our way back to the carpark as the temperature continued to climb in to the high 30s.

It's only a short drive from Jim Jim Falls to the Twin Falls parking area but there's a deep, wide water crossing at Jim Jim Creek, so it's only accessible to vehicles fitted with a snorkel. We stopped just before the crossing for a bite to eat and bumped into a lovely couple driving a well-equipped 200 Series LandCruiser. This was Graeme and Jenny Foster's third LandCruiser and they were enjoying an eight week getaway from their home base on the Mornington Peninsula, Victoria. While we enjoyed our lunch they regaled us with tales of their own Top End adventure; meeting fellow travellers is one of the great things about touring in places like this. Feeling refreshed after lunch, we tackled the water crossing which was deep enough to see a bow

wave lick the bonnet of the D-Max. Behind us, Geoff was having a great time in the HiLux; this was the deepest water crossing he'd driven to date and, with a concrete base, it was good practice for what we would encounter later in the week.

Access to Twin Falls is via a short boat ride (prepaid tickets are available at the Visitor Centre or nearby Garnamarr Campground) operated by local Aboriginal staff. Some time ago you'd access the falls by paddling or swimming to them, but not any more. "Fourteen years ago they used to swim in here," our boat pilot Dennis Miller explained. "There used to be a croc net, across the water and the bank, and you'd come with your kayak on the left-hand side, or blow-up tyre, and swim up here. One day they found a four-metre saltwater crocodile on this side of that net; they tried to harpoon it, the crocodile dug its head, its whole head, under the sand and just lifted up the net and kept on going. So no more swimming."



Clockwise from top:
Twin Falls, Egret at
the waters edge,
Rainbow bee eater,
Water crossing at Jim
Jim Creek.

As we gently motored upstream through the Twin Falls Gorge, Dennis talked about the environment around us, and what it means to the Aboriginal people. "We've got Australia's biggest freshwater turtle here, the Warradjan, that's the pig-nose turtle, and it's the only freshwater turtle in Australia with flippers, like saltwater ones..."

"Did you hear that bird going off?" he asked. "That's the white-line honeyeater. We call it the spirit bird. It's telling the spirits and the ancestors that there's people coming up this river..." Then he points: "You can see slide marks there on the left-hand side where turtles or freshies have been laying eggs..."

I asked if anyone used to live here, Dennis answers, "There's an old occupational site here, fireplaces been carbon dated 50-60,000 years old in here. This area was used for young boys and men; they bring 'em down here and teach 'em how to paint... as well as make spearheads and storytelling."

Camp Facilities

The main campsites in Kakadu are at Merl, Muirella Park, Mardugal, Garnamarr and Gunlom, and facilities include solar heated showers, toilets and washing up facilities. Toilets and showers have wheelchair access. Camping fees of \$10 per adult per night apply at these sites. Free bush camping areas are located throughout the park and facilities range from non-existent to basic.

We stayed at the following:

- Sandy Billabong: The campsite here offers basic facilities (fire pits, tables and toilets) and there were only two other groups camping while we were there – a couple with a toddler and two young backpackers.
- Cooina Lodge Campground: We had a powered campsite at the delightful Cooina Lodge Campground so we could recharge all of Michael's camera batteries. There are all of the usual caravan park facilities here, as well as a restaurant, fuel, airconditioned rooms, swimming pool, gift shop and general store.

You can also book a Yellow Water Billabong cruise at Cooina, giving you the opportunity to see whistling ducks, magpie geese, kingfishers, crocodiles, buffalo jabirus and brolgas.

Call Cooina on (08) 8979 1500 or see the website at www.gagudju-dreaming.com.

- Kambolgie: Like Sandy Billabong, Kambolgie has basic facilities (fire pits, tables and toilets) and we only had to share it with the very quiet occupants of one other vehicle.

Park Pass

A Kakadu park pass costs \$25 and allows you to explore the park for 14 consecutive days. There's no charge for children under 16 and NT residents. You can pick up a pass online at passes.parksaustralia.gov.au/ticketing/ or at the following locations:

- Tourism Top End, corner of Bennett and Smith Streets, Darwin
- Bowali Visitor Centre, Kakadu NP
- Cooinda Lodge
- Aurora, Kakadu South Alligator, Arnhem Highway



Clockwise from left:
Southern entrance to Kakadu NP,
Infrastructure on the walk to Twin Falls, Boat ride to Twin Falls.

“I’ll just show you that picture of the rainbow serpent up here, on the rock... you can see that ochre painting there, that’s rainbow serpent... it was our creator, created our rivers, our gorges and our streams, the rainbow serpent, and he resides in here.”

The boat ride takes around 10 minutes and drops you off with just a short 500m walk over rocks to the pool at the bottom of Twin Falls. Unlike Jim Jim Falls, water cascades over the 120m escarpment here all-year round, although the flows are much reduced in the dry season. Nevertheless, the sound of running water certainly adds to the peaceful feeling as you scan the walls of the escarpment from the white, sandy beach at the edge of the pool, taking in the myriad of colours and shapes of the vegetated rock walls, and their reflections in the still pool.

We spent an hour or so here before we made our way back to the boat for the trip back to the parking

area. Again, if time had permitted, we could have taken on the steep Twin Falls Escarpment Walk, but we would have needed around four hours to do it justice, and we still had to drive back around 60km along the 4WD-only road to the Kakadu Highway, and then another 15km or so to Cooinda Lodge Campground (see sidebar) where we were booked in for the night.

It was dark by the time we reached Cooinda, so we were thankful for the brilliant ARB Intensity LED driving lights fitted to both rigs – they offer serious light output! After fuelling up we located our designated campsite, rolled out our swags, cracked a tinny and reflected on the day that was. Dinner that night was at the Barra Bistro... and the barra was good.

We were up before sunrise again the following morning, scoping out a potential photo location at



Yellow Water Billabong, just a couple of kms up the road. We poked around for a bit but couldn't find the shot we were after in the dark, so we brewed a cup of coffee on Michael's somewhat famous Bialetti and discussed how we should've opted for a couple of hours extra kip instead. Never mind; as soon as the caffeine kicked in we were raring to go once again.

Back on the Kakadu Highway, we headed south for 90km or so, stopping a couple of times to take photos of the massive termite mounds on the side of the road, before we turned left on to the gravel road towards Gunlom. The first section of this road was in reasonable shape, but the 6kms after the T-intersection to Gunlom was rutted and heavily corrugated – road works have reportedly taken place since our visit. With plenty of time up our sleeves, we had lunch in the campground at Gunlom before we loaded up and took on the walk to the plunge pool at the top of the escarpment. According to the

sign at the bottom, this climb is rated as “steep and strenuous”, and by the time we tackled it the mercury was nudging 40 degrees. Even though it only took us around 30 minutes to climb to the top, by the time we got there we were all pretty knackered. Fortunately there are no saltwater crocs here and the cool waters of Gunlom Plunge Pool proved incredibly refreshing. As we soaked in the cool infinity pool, we took in the spectacular views over the South Alligator River valley before us. According to the Jawoyn people, the traditional landowners, Gunlom is part of Buladjang country where the creation ancestor Bula lives under the ground. If Bula is disturbed he can wreak great destruction, so the Jawoyn ask that visitors respect signs that restrict access to specific sites.

Interestingly, Buladjang is known as sickness country and some Bula sites can make people ill if they go there. From a geological perspective, the valley contains rich deposits of potentially harmful minerals – uranium, mercury, lead and arsenic – and there's claimed to be a correlation between the location of major Bula sites and these deposits. It should be noted, however, that there are many parts of sickness country that do not have heavy metal deposits.

The descent back to the carpark was almost as taxing as our earlier ascent, but this time we cooled off by consuming vast quantities of water in the shade of nearby trees. Originally we had planned to camp at Gunlom but on the road in we had spotted a more isolated campsite that appeared better suited to our photographic requirements. Called Kambolgie, facilities here are more basic than at Gunlom – consisting of fire pits, tables and toilets – but we were self-sufficient, so it wasn't a problem. While Michael set up the vehicles to capture some camping shots that evening, we got the fire going and sorted out dinner.

We were treated to another brilliant morning with the sun rising behind the escarpment precisely where we'd predicted (GPS technology is a wonderful thing). Our mission today was to exit Kakadu National Park, fuel up at Pine Creek and then embark on the second part of our Top End Adventure in Litchfield National Park. In three days we'd managed to experience just a few of the highlights of this magnificent part of the Northern Territory, and we were all in agreement that we'd have to come back and explore Kakadu again some time, albeit at a more leisurely pace.

But there was no time for regret; we were on our way to Litchfield NP, and we knew there'd be plenty more billabongs, rivers, swimming holes and off road driving ahead of us.

Part II of Kakadu Dreaming will continue in Issue 43.

MAKE IT



THE MOMENT HAS COME FOR HOLDEN COLORADO AND ISUZU D-MAX OWNERS WITH THE RELEASE OF THE MUCH-AWAITED ASCENT CANOPY.

The Ascent canopy radiates sophistication and innovative styling with qualities such as a vanishing edge design, frameless windows and curved rear door with an invisible hinge.

The functionality of the canopy is as appealing as its sleek style with features including vehicle key operated remote central locking for both side and rear windows to provide higher security and added convenience. Another consumer-focused feature is an automatically activated internal LED light and electronic unlatching of the side lift-up windows and rear door, negating the need for external handles. The Ascent canopy has been designed by four wheel drivers, for four wheel drivers with other great features including a slim line canopy vent and improved sealing to reduce dust ingress, concealed internal fasteners for a visually clean interior and plug-n-play wiring harness for easy installation.

Well-thought-out design inside and out, the unique internal support brackets have also been developed to add strength



and practicality, providing a solid foundation that allows users to choose from a host of roof load carrying solutions. To avoid affecting access to the side window or taking up important internal storage space, the internal support bracket attaches to the strong base rail and window frame. Some of the roof load carrying solutions comprise of steel or alloy trade racks. With a simple design these offer an integrated approach to load carry.

The Ascent canopy has been developed, tried and tested by ARB's canopy team in Melbourne and joins a growing number of cleverly designed accessories available for the Holden Colorado and Isuzu D-Max. Each accessory has been designed in accordance with and tested to Australian standards.

Some of these accessories include:

- Deluxe bar
- Sahara bar
- Commercial bar

- Under vehicle protection
- Air Lockers
- OME suspension
- Rear step tow bar
- Side rails and steps
- Classic canopy
- Ute lids
- Auxiliary battery systems
- Safari snorkel

With exhaustive research, design and testing, the Ascent canopy is the perfect accessory for your vehicle and is backed by a three year, 60,000km warranty.

The Ascent canopy is built to last even in the harshest off road conditions. Whether it's outback terrain or rocky hillsides, 4WD owners can be rest assured that this canopy will thrive in every condition.

CREATURE OF THE NIGHT

This image comes from an expedition with Anne Beadell who was following and discussing Len Beadell's accomplishments for 4x4 Australia Magazine. It was back in October 2008 that we came across this spider, instantly drawn to its amazing colours and markings.

This was late at night after most of the crew had hit their swags. My mate Macca and I were thinking we might have found a new species of spider, so we figured we should grab some interesting images.

So, in the pitch black night, rather than placing a flash on the hotshot of the camera we decided that holding a torch light over the spider would make a more interesting image. Carefully we crawled around the ground trying to capture this spider in all its detail, with an orchlight and higher than usual ISO.

This is a good example of how you can make a subject look better without using your camera's inbuilt or on-camera flash. Admittedly, my cameras do not have inbuilt flash, but I do carry speedlites and expensive portable studio lighting kits with me in the outback and could have created images easier using some of this gear.

However a basic \$10 torch has made this image so much better than what it could have been with a flash unit blasting through the night light. The concentrated, almost theatre looking spotlight creates framing of the subject and encourages a dramatic focus on this Desert Wolf Spider hunting at night.

Michael Ellem, Offroad Images





Camera: Canon EOS 1D MarkIII
Lens: EF 70-200mm f/2.8L IS USM
Shutter Speed: 1/25th of a second
Aperture: f 6.3

Focal length: 95 mm
ISO: 800
Short extension tube added and manually focused

RK11 RECOVERY KIT

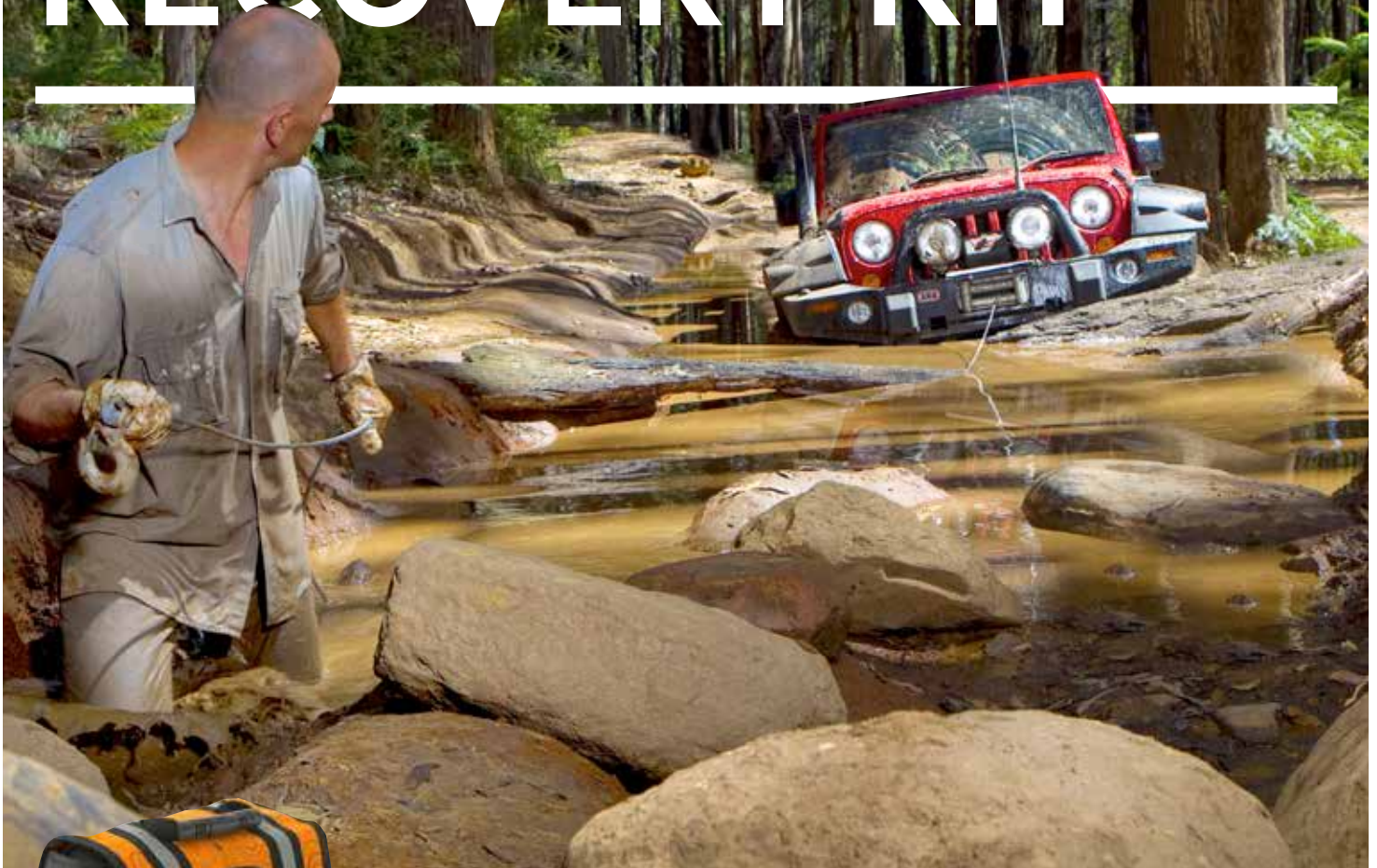

Vehicle recovery is a major part of 4WDing. Without the right equipment, it can become frustrating and even dangerous, but if you're properly prepared, it becomes a challenging yet rewarding experience.

ARB's recovery range is designed to handle any recovery situation. Engineered and manufactured to the highest standards, our recovery gear is ideal for recreational use as well as competition.

After the release of the widely popular RK9 premium recovery kit, ARB is pleased to provide 4WDers with the new RK11 Essentials Recovery Kit.

Utilising a smaller recovery bag, the RK11 can be neatly stored in a standard 220mm high 4WD roller drawer.

Containing an ARB 8,000kg recovery strap, 12,000kg tree trunk protector, 4.75 tonne bow shackles and 9,000kg snatch block, the RK11 recovery kit represents great value and provides you with the necessary gear to get you out of any sticky situation.

PART NUMBER: RK11

PRICE: \$295.00 RRP

Balance of Power



THE NEXT GENERATION IN BATTERY MANAGEMENT SYSTEMS IS HERE, THE MANAGER30.

The highly anticipated Manager30 is a complete 30 amp battery management system for charging auxiliary batteries used in automotive applications by incorporating AC, DC and solar inputs to achieve the best charge.

The Manager30 is designed on a CANbus platform and newly developed electronic current sensing technology makes installation a breeze. The Manager30 is compatible with all vehicles and alternator systems including variable voltage alternators.

A unique feature of The Manager30 is that it has been designed to charge an auxiliary battery from multiple sources simultaneously. If 12 volt solar power

input is available, solar power will be used as a priority before 240 volt mains (if available) or DC vehicle power, when on the move.

Designed and manufactured in Australia, for Australian conditions, using the latest electronic and design technology, the Manager30 will get you to where you want to go – and get you back again – with complete confidence.

Five products in one

- DC in-vehicle battery charger
- 240 volt AC battery charger
- MPPT solar regulator
- Dual battery isolator
- Remote battery monitor

Contact ARB for part numbers and pricing.

Built To Be Red!

Introducing new
REDARC 52mm
gauges.

Tailored to meet the requirements of 4WD and camping enthusiasts. REDARC gauges are ideal for monitoring vehicle health, including battery voltage, current draw, exhaust gas temperature (EGT), manifold boost and vacuum pressure, oil pressure and a range of temperature applications such as outside, cabin, oil, water, coolant and fridge temperatures.

This extensive range of LCD/LED gauges are Australian made and combine dual or triple functions in the one 52mm gauge.

With 12 variants to choose from, each has a choice of 13 custom backlight colours, programmable alert levels as well as relay

output and peak hold functions on all variants (except voltage gauges).

Simple to install and operate, REDARC also offer a range of optional sensors, mounting solutions and accessories.

The extensive range of gauges are designed and manufactured in Australia for Australian conditions. Regardless of the gauge you choose, you'll be assured of the high quality and reliability that comes with every REDARC product.

Voltage Gauges –

G52-VA and G52-VVA



Ideal for battery systems mounted in 4WDs, campers, caravans, motorhomes and similar vehicles, the LCD/LED display allows you to monitor the charging performance of your main and/or auxiliary battery. Voltage gauges can also be equipped with an optional 100amp rated current display (sold separately) that monitors the amount of current to or from your main or auxiliary battery.

EGT and boost pressure gauges –

2-EB, G52-BET, G52-BEA and G52-BEP



A must for your turbo-charged diesel vehicle; used to monitor the exhaust gas temperature (EGT) of turbo-equipped vehicles in conjunction with a pyrometer probe.

The boost pressure function monitors manifold air pressure and is used to ensure excessive pressure is not generated.

The gauges are supplied with a 'K' type EGT sensor and electronic boost MAP sensor interface. The boost has a peak hold function with a display range from 0-45psi and programmable alert level between 10 and 30psi.

All gauges have a programmable alert between 500 and 800°C. The EGT probe has a 1/8" NPT compression fitting and are supplied with a weld-in mounting bung.

EGT and boost/vacuum Temperature gauges –

G52-EU



The G52-EU boost/vacuum gauge shows the difference between outside atmospheric pressure and the amount of vacuum present in the intake manifold.

The gauge is supplied with a 'K' type EGT sensor and electronic boost MAP sensor interface.

The boost/vacuum has a peak hold function with a display range from -12 to 23psi and programmable alert level between -5 and 25psi.

The EGT function also has a peak hold function with a range from 0 to 1,000°C and has a programmable alert between 500 and 800°C. The EGT has a 1/8" NPT compression fitting and is supplied with a weld-in mounting bung.

Temperature gauges –

G52-TA and G52-TTT



Ideal for monitoring your engine's oil and/or water (coolant) temperature. The G52-TA gauge is supplied with one REDARC 1/4 NPT thread temperature sensor that measures from 30 to 160°C and can also be equipped with an optional 100A rated current display (sold separately) that monitors the amount of current to or from a battery.

The G52-TTT gauge is supplied with two REDARC 1/4 NPT thread temperature sensors that measure from 60 to 150°C. The G52-TTT gauge also supports one of four optional temperature sensors (sold separately).

Oil pressure gauges –

G52-PT, G52-POT and G52-PWT



Ideal for monitoring your engine's oil pressure. All oil pressure gauges are supplied with one REDARC 1/8 NPT thread 150psi oil pressure sensor. G52-PT is a single oil pressure gauge that displays from 0 to 130psi.

G52-PWT is a dual oil pressure gauge that displays from 0 to 80psi. It is supplied with a 1/8 NPT thread water temperature sensor that displays from 30 to 120°C to also monitor coolant temperature. G52-POT is a dual oil pressure gauge that displays from 0 to 80psi. It is supplied with a 1/4 NPT thread oil temperature sensor that displays temperatures from 60 to 150°C.

All oil pressure gauges support one of four optional temperature sensors (sold separately) to measure water, oil, cabin, fridge, or outside temperature.

A NEW PERSPEKTIV

Capture your active life. Thule's Perspektiv range has backpacks, daypacks, slings and toppers to get you and your photo gear up the mountain or down the slope safely and in style. With smart features for safe camera storage and fast access, plus customisable spaces for your essentials and accessories.

Steeped in proven Thule quality and Scandinavian design, each piece in the Perspektiv collection effortlessly combines function, meticulous attention to detail, and progressive styling to help you easily integrate photography into your active lifestyle.



**THULE PERSPEKTIV
BACKPACK**



**THULE PERSPEKTIV
DAYPACK**



**THULE PERSPEKTIV LARGE
TOPLOADER**

From camping on safari in Tanzania to exploring the Galapagos Islands, the Perspektiv Backpack is the perfect travelling studio to carry everything you need to document your adventures without missing a shot. Use back-access to easily get to or secure your DSLR camera and gear. By customizing the pack's storage configurations, you can quickly find and grab the essentials.

You, three friends, and the ultimate photo daypack. Capture the action and beauty while hiking through the bush or documenting your buddy's adventure race finish. Easy access to key equipment means you'll have plenty of time to set up the perfect sunrise shot, while additional storage houses an extra layer when the weather takes a turn for the worse.

Keep snapping away without missing a face shot thanks to this topper's surefire support and versatile carrying configurations. Easily fit and access your prosumer DSLR body with battery grip and attached lens (up to 70-200mm f/2.8) to ensure you don't miss a beat.



**THULE PERSPEKTIV MEDIUM
TOPLOADER**

Effortlessly carry essential photo gear to capture every single frame, regardless of your chosen adventure. Carry your prosumer DSLR body and ultra-wide-angle lens, and enjoy fast and easy access when it matters most.



**THULE PERSPEKTIV
MESSENGER BAG**

The Perspektiv Messenger leads a double life—use it as a pure courier bag for your daily commute or on the weekends as a mobile camera studio to snap pictures for your evolving album.



**THULE PERSPKETIV ACTION
SPORTS CAMERA CASE**

Bring along your GoPro® gear to record every second of excitement. Fit all those different mounts and housing options, plus your wall charger, and head out to your next destination to do it all over again.

Words by Dean Mellor
Photography by Offroad Images

C CROSSING V E R E D

WATER CROSSINGS CAN BE SOME OF THE MOST INTIMIDATING CHALLENGES YOU'LL FACE AS A FOUR WHEEL DRIVER, BUT WITH THE RIGHT EQUIPMENT AND THE RIGHT APPROACH, YOU SHOULD HAVE NO PROBLEMS GETTING SAFELY TO THE OTHER SIDE.

One of the key pieces of equipment in your water crossing arsenal is a water crossing cover, and ARB has recently developed a new and innovative version of this important bit of gear.

Whether or not you have a snorkel fitted to your four wheel drive, a water crossing cover (sometimes called a radiator blind) is the most effective way to keep water out of your engine bay, where it could otherwise cause damage to several components in any modern vehicle. While a snorkel's role in a water crossing is obvious – to prevent your vehicle's engine from ingesting water through its air intake – a water crossing cover's role is to direct water around the engine bay rather than through the radiator. This is important for a number of reasons.

Firstly, if water passes through the radiator and hits the nylon/plastic blades of your vehicle's cooling fan, those flexible blades can bend forward and cut into the radiator, resulting in rapid coolant loss and a premature end to your trip.

Secondly, by directing water around the engine bay rather than through the radiator, the water crossing cover will help keep water away from your vehicle's sensitive electrical components, such as the ECU and, in the case of petrol engines, the ignition system.

The new ARB Water Crossing Cover is designed to fit snugly and securely to the front of your vehicle, regardless of its width and whether it is equipped with a bull bar or not.

Made from a tough Nylon material, the ARB Water Crossing Cover has several unique features that make it easy to carry, easy to fit and easy to use.

It is supplied in a durable orange carry case with ARB's distinctive topographic contour design so you'll be able to locate it quickly in a packed vehicle. The cover then unpacks from a small pouch that doubles as a snatch-strap pocket once it's been fitted to your vehicle. Elasticised edges

GS



help it conform to the shape of the vehicle, and long retaining straps wrap around the side mirrors and then secure back towards the centre of the cover via robust plastic clips. These clips are then secured with Velcro retaining covers that prevent damage to the vehicle's paintwork.

The entire fitting process can easily be performed by one person, in just a couple of minutes. Once fitted, you'll immediately notice another great feature of the ARB Water Crossing Cover; clear PVC inserts at the headlights. The benefit of these is obvious to anyone who's had the misfortune of having to negotiate a river crossing in dim light.

There's also the aforementioned snatch-strap pocket, that allows you to pre-attach your strap to the recovery point on your vehicle and safely stow it in this easily accessible pocket in case the crossing doesn't go to plan.

Finally, the bottom section of the ARB Water Crossing Cover is made from a robust mesh material that's designed to allow water to flow away once the crossing has been completed.

Once you're safely on the other bank, repacking the ARB Water Crossing Cover

is a simple affair; unclip the retaining straps and fold it back into itself, and it's fully contained in the snatch-strap pocket. Voila!

TOP 5 WATER CROSSING TIPS

- 1 **Check the depth**
If it's safe to do so (ie. there are no saltwater crocodiles) you should walk unfamiliar crossings before driving them to gauge the depth and look for submerged obstacles.
- 2 **Cool down**
Let your vehicle cool down before plunging into a water crossing. A hot gearbox, transfer case, differentials and hubs will want to suck in cold water past their respective seals, causing damage down the track.
- 3 **Fit a water crossing cover**
A water crossing cover will direct the water around your engine bay rather than through the radiator, preventing damage to the radiator and electrical components.
- 4 **Engage locker(s) if fitted**
If the surface beneath the water is particularly rough or muddy, you'll need all the traction you can muster, so engage those air lockers before diving in.
- 5 **Constant speed**
Select a speed that builds up a decent bow wave in front of the vehicle and stick to it; not so fast that water is flowing over the bonnet and not so slow that the water crossing cover won't work as it's designed to. Second gear, in low range usually results in the most appropriate speed.

BUSHRANGER EASTER SPECIALS

**SPRING INTO
EASTER WITH
THESE GREAT
BUSHRANGER
SPECIALS.**

Promotion ends Saturday, April 11 2015.

9,000LB WINCH



- Tough aluminium alloy die cast housing
- Superior torque output and fast line speed
- Thermal overload indicator
- Australian engineered, impact resistant alloy control box
- Outstanding structural durability
- Versatile control box mounting
- Patented gearbox mounted automatic cone brake
- Low amp draw

\$999.00

**BUSHRANGER
EASTER
SPECIALS**

GAS HOT WATER SHOWER

- Quick and easy setup
- Instantaneous portable hot water
- Digital temperature display
- Maximum temperature cut out
- AS2658 gas compliant

\$399.00



MAX AIR III COMPRESSOR

**BUSHRANGER
EASTER
SPECIALS**



- Trigger style inflation gun with locking lever
- Built-in pressure switch and deflator button on trigger
- Suits any 12V application utilising battery clamps
- Has total reach of over 11.5m
- Robust carry/storage bag for compressor protection and storage
- Thermal overload protection switch
- Backed by a 5 year warranty

\$299.00

ARB BURNIE



Located on the north west Tasmanian coast, about 40 minutes from Devonport, is the beautiful town of Burnie. Home to 20,000 residents, this idyllic town is surrounded by dazzling beaches, beautiful gardens and an equally impressive container port.

Just two minutes from the heart of the city is ARB's newly appointed 4x4 Accessories Burnie store, just off the Bass Highway on Edwardes Street. Servicing the local farming and mining community as well as 4WDing enthusiasts, ARB Burnie is quickly becoming the go-to supplier for all 4WD adventure needs.

Simon Limbrick, ARB Burnie's branch manager, has been with ARB for nine years and recently relocated from Launceston. "We're a close knit team here at Burnie," says Simon. "We're all very passionate about 4WDing and have a strong focus on personalised, friendly customer service."

The team at ARB Burnie love to spend their spare time on the road, from touring the Tarkine to tackling the tracks on the way to Sandy Cape. Amy, ARB Burnie's retail sales rep is an experienced 4WDer, regularly hitting the tracks in her 80 Series LandCruiser.

So next time you're enjoying the gorgeous scenery of Burnie, pop into our ARB store and say g'day!

ARB Burnie
1A Edwardes Street
South Burnie, TAS 7320
Ph (03) 6431 4494
Fax (03) 6431 2724

ARB Burnie stocks ARB's full range, including:

- ARB Bull Bars
- Electric Winches
- ARB & IPF Lights
- ARB Under Vehicle Protection
- ARB Side Rails & Steps
- ARB Rear Bars & Rear Wheel Carriers
- Hayman Reese Tow Bars
- ARB, Thule & Rhino Roof Racks
- ARB Canopies, Ute Lids & Ute Liners
- ARB Air Lockers
- ARB Air Compressors
- Old Man Emu Suspension Systems
- ARB SkyDome Swags & Rooftop Tents
- ARB Recovery Equipment
- ARB Fridge Freezers
- Outback Solutions Drawers
- ARB Auxiliary Battery Systems
- Safari Snorkels
- Fuel & Water Tanks
- GME Radios, Recaro Seats, Cargo Barriers and more.

KEEP BUSY DURING THE NEXT FEW MONTHS WITH THESE EVENTS.

WHAT'S ON

APRIL

Sydney Caravan, Camping & Holiday Supershow

11-19 April
Parramatta NSW
www.caravan-camping.com.au/supershow

South QLD Caravan, Camping, Boating & Fishing Expo

17-19 April
Nambour QLD
www.caravancampingexpo.com.au

JUNE

ARB Tamworth Open Day

13 June
Tamworth NSW
www.arb.com.au/stores/arb-tamworth

MAY

East Gippsland Field Days

1-2 May
Bairnsdale VIC
www.egfielddays.com

Agfest

7-9 May
Carrick TAS
www.agfest.com.au

Cairns Homeshow & Caravan, Camping & Boating Expo

15-17 May
Cairns QLD
www.cairnshomeshow.com.au

Albury Caravan, Camping, 4WD, Fish & Boat Show

15-17 May
Albury VIC
www.ruralscene.com.au/events/caravan-camping-4WD-fish-boat-show/albury

Mackay Homeshow & Caravan and Camping Show

22-24 May
Mackay QLD
www.mackayhomeshow.com.au

Explore Australia Expo

29-31 May
Flemington VIC
www.exploreaustraliaexpo.com.au/melbourne



ISUZU PROTECTION

In addition to ARB's already extensive protection equipment line-up, Isuzu enthusiasts now have a greater range of ARB product options available, following the release of the D-Max Sahara bar and the MU-X Deluxe bar.

These steel constructed bars not only provide additional protection options for Isuzu owners, but are both designed with innovative features aimed at making remote area travel safer.

ARB bull bars are an essential asset to any off road vehicle. Not only do ARB bars provide ultimate protection for your vehicle and its passengers, they also provide a solid platform to mount all of your favourite off road accessories.

The advanced design and engineering of the D-Max Sahara bar and the MU-X Deluxe bar allow fitment of many off road necessities for both experienced and novice drivers. A large selection of Warn, Magnum, Smittybilt and Bushranger winches can be fitted onto both bars as well as a large range of IPF driving lights,

ARB Intensity LED lights and ARB Fog Light Kits. In addition to this, two aerial mounts are welded to the centre cross tube.

The mounting system used for both the D-Max Sahara bar and the MU-X Deluxe bar has been superbly designed for general use and winching, whilst ensuring air bag triggering is not compromised.

ARB's renowned multi fold upswept and tapered wing design is used for both bars, aimed to enhance optimum strength and approach angle. Other pioneering design features include the continuous uprights through the bumper section which strengthens the outer frame of both bars, as well as the split pan design, aimed at maximising the strength and airflow of the bars.

For additional safety, extensive under protection panels are present which can be located in the centre and either side of the bars. Twin Hi-Lift jacking points are another key feature and are located in the pan of both bars.

Both bars have been carefully engineered and manufactured to not only maintain maximum functionality, but also to ensure that each bar maintains a vehicle-specific design that will therefore complement the look of the D-Max and MU-X vehicles.



D-Max Sahara bar specific

After ARB recently launched the D-Max Deluxe bar, the latest Isuzu D-Max now has two bull bar options following the release of the D-Max Sahara bar. Sharing many strength-related features of the D-Max Deluxe bar, the D-Max Sahara Bar offers a different look without sacrificing practicality or safety. All D-Max Sahara bars allow fitment of essential 4x4 accessories such as driving lights, winches and fog lights, and are finished in a hard-wearing millennium grey powder coat with the added option of colour coding if desired.

MU-X Deluxe specific

ARB has finally announced the completion of the MU-X Deluxe bar, after months of design and engineering. The Deluxe bar is the first of many protection equipment products that ARB has launched for the Isuzu MU-X. Incorporating ARB's new fog light and LED indicator and surrounds, with each wing of the bar featuring ARB's LED clearance light and turn signal in a press form opening.

The MU-X Deluxe bar includes laser cut holes in the top of the centre pan for fitment of a range of compatible driving lights. The bar boasts other essential safety features such as cover straps that are attached to the uprights and a slotted design for the lower centre stone guard, ensuring adequate vehicle cooling. All MU-X Deluxe bars allow fitment of other essential off road gear such as winches, and are finished in a hard-wearing satin black powder coat with colour coding as an optional extra.

Other ARB products for the Isuzu D-Max and MU-X vehicles*:

- ARB Deluxe Bar
- ARB Commercial Bar
- ARB & Thule Roof Racks
- ARB Canopies & Canopy Accessories
- ARB Ute Lids & Liners
- ARB Air Locker Locking Differentials
- Old Man Emu Suspension Systems
- Outback Solutions Drawers
- ARB Auxiliary Battery Systems
- Safari Snorkels
- Fuel & Water Tanks
- ARB Under Vehicle Protection
- ARB Side Rails & Steps
- Hayman Reese Tow Bars
- Kaymar Rear Bars
- ARB Rear Step Tow Bars
- Electric Winches
- ARB & IPF Lights

*not all products are available for Isuzu MU-X, visit www.arb.com.au or head into your local ARB store for more details.

ON

**DO YOU KNOW YOUR
CSC'S FROM YOU DSLR'S?
+
DO YOU NEED A WIDE ANGLE
OR TELEPHOTO LENS?
+
MICHAEL ELLEM CUTS THROUGH
THE JARGON AND PROVIDES
AN IN DEPTH LOOK INTO WHAT
YOU SHOULD CONSIDER WHEN
GETTING STARTED.**

CA



**WORDS AND
PHOTOGRAPHY
BY MICHAEL ELLEM,
OFFROAD IMAGES**

MERAA

A silhouette of several photographers and a tree against a sunset sky. The photographers are standing on a horizon line, some with tripods and cameras. The tree is on the right side, with its branches reaching across the sky. The sky is a gradient of orange, yellow, and blue.

What camera should you buy to get started?

This would have to be the number one question I get asked.

It's a fabulous question which I enjoy responding to with a series of questions relating to size, budgets and features. It's important for me to get an understanding of what you think you will be doing with this camera and I have been known to speak with budding photographers for over an hour assisting them with the answers to their questions.

In this article, I will try to provide you with information to point you in the right direction for your future photography goals. Firstly we have the following styles available to us:

Smartphones (the camera you will most likely always have with you)

Smartphone manufacturers are now creating image capture devices which are used by most of modern civilisation to assist them in sharing their lives. These smartphones are really more like compact cameras than ever before and I believe they have taken over much of

the compact camera marketshare.

Compact cameras (I call these happy snap cameras)

This probably sounds a little arrogant, but the reality is that some smartphones can do the job of these compact cameras and I believe that users would be more likely to take their smartphone out of their pocket and capture better images than that of the 'basic' Compact Cameras. Therefore I wouldn't recommend heading along this line, as in reality, it would get less use than your smartphone. There are better Compact Cameras around on the market, but they tend to carry a price point which is getting up there with the Compact System Cameras (CSC's) and smaller Digital Single Lens Reflex cameras (DSLR's).

Compact System Cameras (CSC's) (mirror-less system including the micro four-thirds)

The wording Compact System Camera is completely suitable as these systems are compact all the way from the body to the lenses and accessories... these are extremely compact units which are easy to hold and store during your travels. The mirror-less design means that all viewing of

the images is handled through LCD displays either when looking through the viewfinder or the screen on the back of the camera. The fact that these cameras are mirror-less systems means that the size of the cameras can be reduced, creating compact cameras which can be carried easier. These compact systems have the benefits of interchangeable lenses meaning that you will have the ability of capturing much better imagery for the look required. Something that many people do not understand is why you need to carry so many lenses. The compacts which have an inbuilt lens system can have a huge zoom coverage, allowing them to capture extremely wide angle to long telephoto imagery. It will not capture as sharp and clean images as a camera system which uses multiple lenses to do the same job. So the ability to be able to change the lens system from wide glass to suit a wide image view to a telephoto glass to suit telephoto image view, will create better quality images. The same works with DSLRs also. So don't buy glass with huge magnification range capabilities as it brings with it a shortfall in quality.

Digital Single Lens Reflex cameras

(DSLR's) The SLR or Single Lens Reflex camera has been effective for many years back in the film days and has been made even better with the advent of digital technologies. It works with a mirror behind the lens reflecting the exact image that you are looking at upwards to a prism, which is then reflected through the viewfinder to your eye. When you press the shutter button the mirror lifts upwards and allows light to pass through to the image sensor. Amazingly, this happens whilst you might be rattling off as many as 12 frames per second for example, and at the same time, continually tracks focus and exposure each time the mirror drops back down – I still have trouble understanding how these cameras can achieve this. It always makes me smile to see how such an old design, made better, works so well. So with the DSLR comes the ability to have interchangeable lenses to suit the style of photography you are looking at achieving. For the amateur or enthusiast, the sensor might be an APS-C which is a smaller sensor or it could be full sized for the semi-professional DSLR's. The larger sensor usually carries an increase in price point.



Pro DSLR cameras These are usually much bigger camera bodies and they also contain better sensors, usually full frame sensors, better focusing systems, better computing and buffers for faster reads/writes and sometimes dual processors to separate focusing and normal camera operations and better water proofing or resistance allowing you to shoot in extreme conditions. They may carry bigger battery systems to handle longer shooting/focusing etc. They may also carry duplicate control buttons so you have easy access to the same functions when shooting portrait or landscape whilst rotating the camera, so your hand will be in the same position. It may also carry better build quality and the durability should be improved with a stronger chassis and grips etc.

So these are the cameras available, but which camera is best for you?

When considering this question, firstly, you must look at the reality of the camera's physical size, as this could be a huge

component in your decision making. You have to carry this around with you, so lets look at this to start with. If you are looking at climbing mountains, you may not want to cart a huge camera around. So where you'll have limitations to camera sizes and weights, you don't want the largest DSLR camera with multiple lenses. Believe me, I have carried some extremely large backpacks of cameras and lenses on some treks around our fabulous country and I know first hand that carting over 30kgs of gear will test your fitness. You might also be looking at the camera simply occupying space in your handbag whilst on your travels, and being brought out to capture that important moment. These two situations require a compact system camera which could be basic or fully featured. Again, I would recommend that if you're serious about photography, even as a hobby, you should look at a system with switchable lenses. But if the size is critical and you need an all in one... you have the answer to your question.

You might have no problem carrying a small camera bag of the necessary gear required to suit your needs. Therefore a smaller DSLR plus lenses would most likely suit this requirement. On the other hand, you might have plenty of space in your 4wd to carry photography gear during your travels, and therefore aren't concerned about what equipment you carry.

So if size is an important issue, but you have room for additional lenses and accessories, the compact system camera would be a great starting point. You can achieve extremely good results with a camera half the size of a DSLR set-up and with the touch-screen controls working much like a smartphone, you will find the systems intuitive.

So if you are not concerned about the size and space and are looking at a DSLR, most entry-level DSLRs are really good and easy to understand nowadays. Some even have features similar to smart

phones with touch screen and swiping capabilities added for moving through images and accessing menus. You might think that you don't need these, and for my cameras, I don't need touch screen at all, but for someone who is using a smartphone regularly, who wants to move into photography, this familiarisation takes away some of the new system learning frustration.

Apart from the physical size, which has its obvious importance, the next question would be what are you planning to photograph? Will you be photographing scenery, wildlife, family etc.? Is this a happy snap kind of camera, or are you interested in learning photography to enable yourself to create better images for social media? Perhaps you are looking at trying to start a career in photography.

Obviously, any of these will also play a part in pricing. So the next item is budgets. You should set yourself a budget to get yourself started and stick to it. CC's, CSC's and DSLR's all have their varying price points to suit their market. This means that any budget can be filled by a number of these systems. So if you are new into photography, you probably don't need a pro lens for all scenarios.

Being new to photography, you may not know what sort of imagery preference you will have. My recommendation to most people I speak to is to start with cheaper lenses whilst working out what style of photography they are interested in. After a period of photography practise and participation, you might see a preference to photographing wildlife, if so, you should put your money towards a better quality telephoto lens to suit this requirement which will ensure that you are enjoying yourself more with your gear. On the other hand, if you are interested in travel and love landscapes, heading towards better wide angle lenses will assist your enjoyment and provide better results. So it would make perfect sense to start with a camera that has a couple of 'kit lenses'. These are cheaper lenses, that you are not paying much for, but will assist you in discovering your style and image preference. This relates to CSC's and DSLR's. There is no point buying the fastest, best, most expensive lens if you

are not going to use it.

Is it all about megapixels? Please don't get caught out by comparing megapixels over camera functions etc. There is and always has been a difference between the megapixel ratings of cameras, but that doesn't mean that the higher megapixel model will produce a cleaner, sharper more effective result.

I never wanted to get into recommending brands of cameras, so I do apologise for this but I believe that the healthy market competition is keeping the manufacturers advancing in technologies and price point, these manufacturers are putting together great systems or kits to suit your budgets, so take advantage of that to help you get started. But keep in mind that once into a branded system, you will be there for some time as these lenses are usually not interchangeable.

So if you are interested in getting more out of your photography and are ready to choose a camera system, please ensure that you have the following features to ensure that you can achieve goals towards

becoming an amateur, semi-professional or professional photographer.

- Aperture controls or program
- Shutter speed controls or program
- Manual mode
- Ability for longer exposure (bulb)
- Easy adjustment for ISO
- Exposure compensation controls
- Hot shoe for flash control

Most cameras will have these features, but sometimes people can struggle with the generic program modes like 'running man' or the program 'mountain range', what is the camera actually doing here? Do we really need these?

You need to decide for yourselves.

But you should understand how to get the best out of your camera... whatever camera you have purchased.

I hope this all helps, but any questions can be directed to myself on Facebook and I would be glad to assist you further.

- Michael Ellem



HEY KIDS, FOURBY HERE!

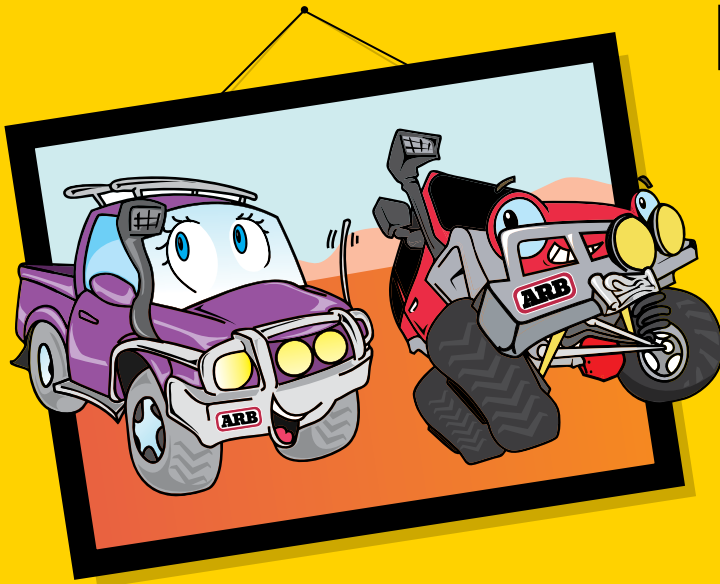

We just love getting all of your fantastic drawings each month. Keep sending them through everyone!



Lachlan

Lachlan sent us this awesome drawing of his mums Nissan Patrol 2008 Turbo Diesel on a recent camping trip (age 10).



Alex

Here's a photo of 10 year old Alex, holding the fantastic catalogue he drew for an ARB open day. Awesome work Alex!



Raveen

6 year old Raveen sent us in this fantastic drawing of a 4x4 race. Thanks Raveen!



Riley

I love camping and four wheel driving and recently did Duck Creek Road and the Condimine gorge river run with 14 creek crossings (age 7)

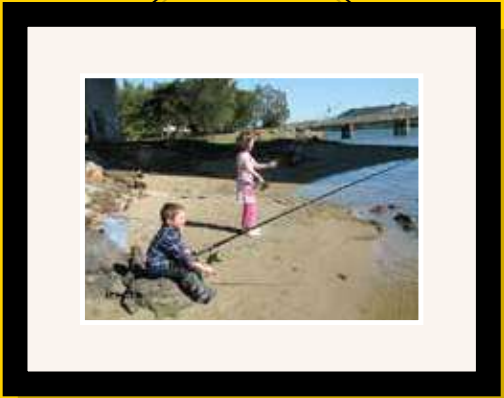

Cooper & Ella

Mum took us fishing under the bridge at Chinderah, it was so much fun. We love outdoors and love your kids page.



Tahlia

Tahlia and her Dads 4WD on One Mile Beach, NSW



Amy

This is my Dad and Grandad in their Jeep Cherokee, driving near Uluru (age 10)

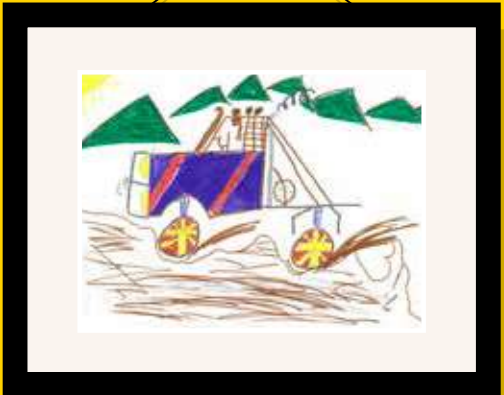

Jon

My dad takes me into the bush with his cool Mitsubishi Triton (age 8).

THE ADVENTURES OF FOURBY AND FRIENDS



FOURBY AND ARIEL SPENT THEIR CHRISTMAS HOLIDAYS AT THE BEACH.



THEY ALWAYS ENJOY SPENDING TIME OUTDOORS, THERE IS JUST SO MUCH TO DO!



THEY BOTH LOVE BUILDING SAND CASTLES



DRIVING UP AND DOWN THE BEACH IN THE WATER'S SHALLOWS



MAKING NEW FRIENDS



WRITING THEIR NAMES IN THE SAND



FINDING ALL THE PRETTY ROCKS AND SEASHELLS ALONG THE BEACH.



EATING FISH AND CHIPS.

WATCH OUT FOR THE SEAGULLS FOURBY!



FLYING THEIR BRIGHTLY COLOURED KITES



AND AFTER A LONG, FUN DAY PLAYING ON THE BEACH, WATCHING THE SUN SET OVER THE WATER.

FOURBY AND ARIEL JUST LOVE THEIR HOLIDAYS!

ARB KIDS

WORD SEARCH

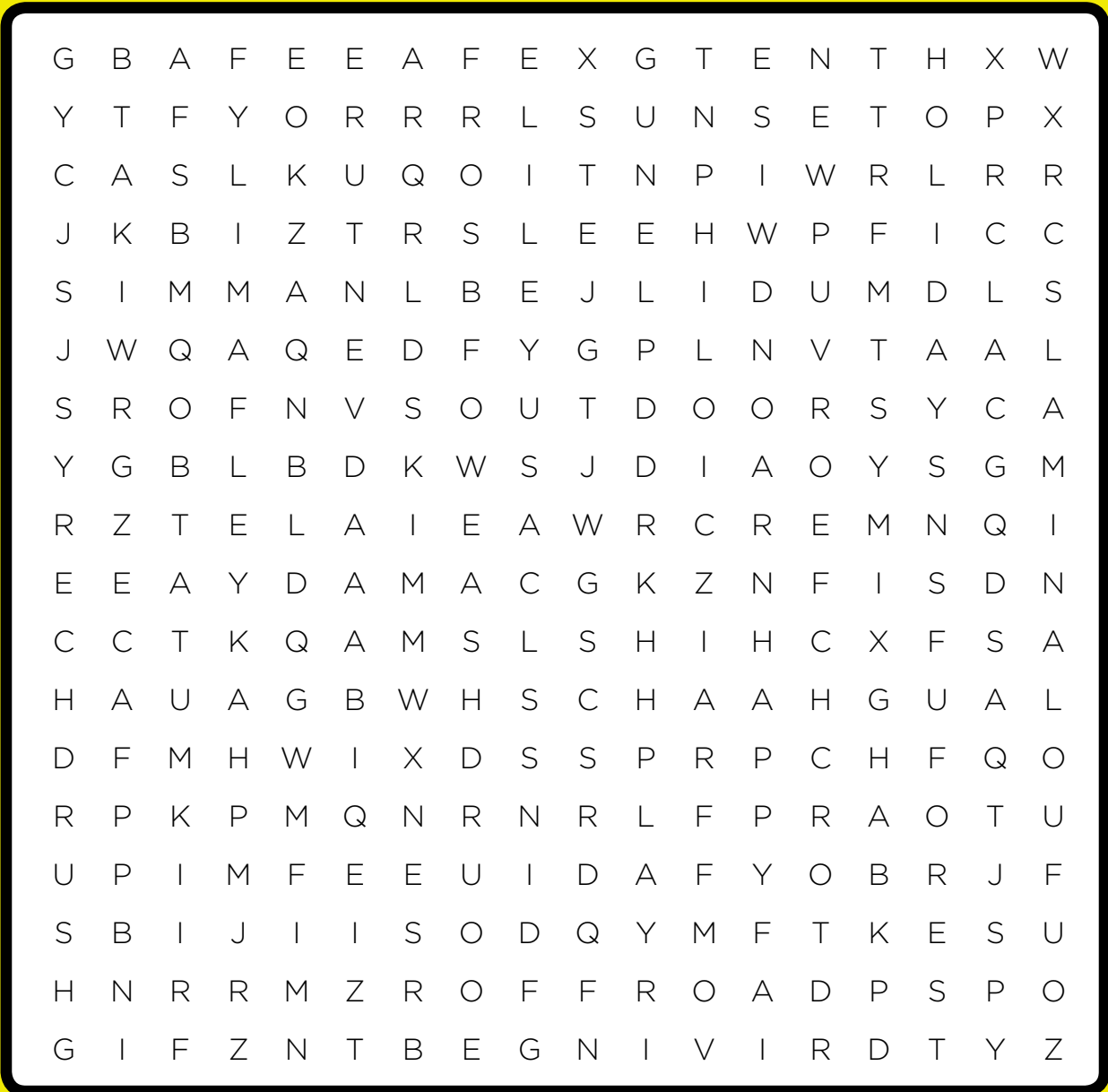

Adventure
Animals
Ariel
Beach
Campfire
Camping
Driving

Family
Forest
Fourby
Fridge
Friends
Fun
Games

Happy
Holidays
Laugh
Marshmallows
Offroad
Outdoors
Play

Racing
Road
Sunset
Swag
Swimming
Tent
Sunshine

Torch
Tracks
Water
Wheels

RUN EMU RUN

Words and Photography
by John Denman



THERE WOULD BE VERY FEW (IF ANY) FOUR WHEEL DRIVE OWNERS WHO HAVE NOT HEARD OF OR COME INTO CONTACT WITH WHAT MANY BELIEVE TO BE AUSTRALIA'S BEST QUALITY AFTERMARKET SUSPENSION. OLD MAN EMU HAS BEEN A BRAND NAME AND A BYWORD FOR A LOT MORE YEARS THAN I'D LIKE TO ADMIT TO, AND IN THAT ERA THE PRODUCT OFTEN SEEMS LIKE ITS APPEAL JUST GROWS WITH TIME.

Like most, I'm no stranger to the brand and have owned a few vehicles fitted with the OME kit. The Pajero I drive had an OME kit fitted back in 2005, and at that time I was a freelance photo journalist and travelled widely and often to all parts of Australia in pursuit of stories for a range of magazines like *Overlander*, *Outback* and *Truckin' Life*, to name just a few.

The kit actually came off a long term test vehicle that we had in the stable at *Overlander* at the time before being returned to Mitsubishi, and had already run up about 40,000km that included an expedition into the Gibson Desert. At the time I probably expected to be lining up for a new kit after I'd put another 50-60,000km on it. I was wrong. To date that kit has totalled well over 300,000km. The only work done was to fit a new rear coil and to fit new bushes to the rear shocks.

Now if you consider the sort of work a 4wd does in the environment I worked in, you could understand if the shocks gave out at maybe 150,000km. The vehicle has also travelled the Gunbarrel Highway, the Tanami Track, The Great Central Road and any number of secondary roads, station tracks, creek and river crossings that cropped up in the course of doing business in the bush.

For the most part my Pajero has been loaded and ready to go pretty much all the time. The suspension gets very little respite from either the elements or hard

work, and has defied everything thrown at it. I maintain my vehicle well, I have to considering the use I put it to, and regular checks on the suspension are all part of that maintenance. We've found no oil leaks, the gas in the Nitrochargers has never leaked and the stone guards have done their job at keeping gravel at bay.

I retired from the journalism business a little while back, but I hung onto the Pajero because it's reliable and has the right blend of power and economy I like. These days it's mostly found getting into the back paddock of a property way out west in pursuit of feral pigs or accessing a remote stream for some bass fishing. It also sees a lot of time towing my boat to North Queensland for some barra fishing. So while I may have retired, the Old Man Emu kit under my Pajero most certainly hasn't. It is still delivering the goods.

I didn't write this to curry favour with ARB, they are one of the great Australian companies and don't need any help from me. I wrote it because the suspension in your vehicle is one of those all-important links between you and the road, and should never be taken cheaply. To run up over 300,000km on a 4WD suspension, considering the work this one has done, it is something to be proud of. Someone once said that bad news usually travels faster than good news, in my opinion it should be the other way around.





Tongmaster Competition

Send us in a photo of your best spit, roast, jerk, tandoor, grill, braai, or bbq setup for your chance to win an ARB Tongmaster Apron. Email your photo, name and address to promotions@arb.com.au

Eldee Easter Event

**It's nearly that time
of the year again. Pack
the 4WD, round up
the troops and get ready
for a weekend of off
road racing and tasty
chocolate.**

Running from April 3-5, the ARB Eldee Easter event is a favourite amongst 4WDers who enjoy a weekend full of challenges, family fun, and of course Easter eggs.

Located near Broken Hill NSW, Eldee Station is the perfect getaway this Easter long weekend. Be mesmerised by Eldee Station's incredible surrounds and take part in the off road action, or come along as a spectator. Owners Stephen and Naomi Schmidt have welcomed 4WDers to their picturesque property for a number of years and make for the perfect hosts. On offer are plenty of food and accommodation packages to suit each individual, including a range of powered and unpowered sites.

The diverse trails and extreme terrain are great for the friendly competition, which are set up by 4wdTV's Simon Christie. Test your skills on a number of different challenges throughout the weekend. The entertainment continues well into each night with a trivia session, scenic sunset tour and a two course dinner on Sunday night.

No matter your level of 4WD experience, this fun filled event is the perfect way to spend the Easter long weekend with family and other 4WD enthusiasts.



ARB Website

After more than 18 months of research, planning, designing and building, ARB is excited to launch its completely redesigned website.

arb.com.au

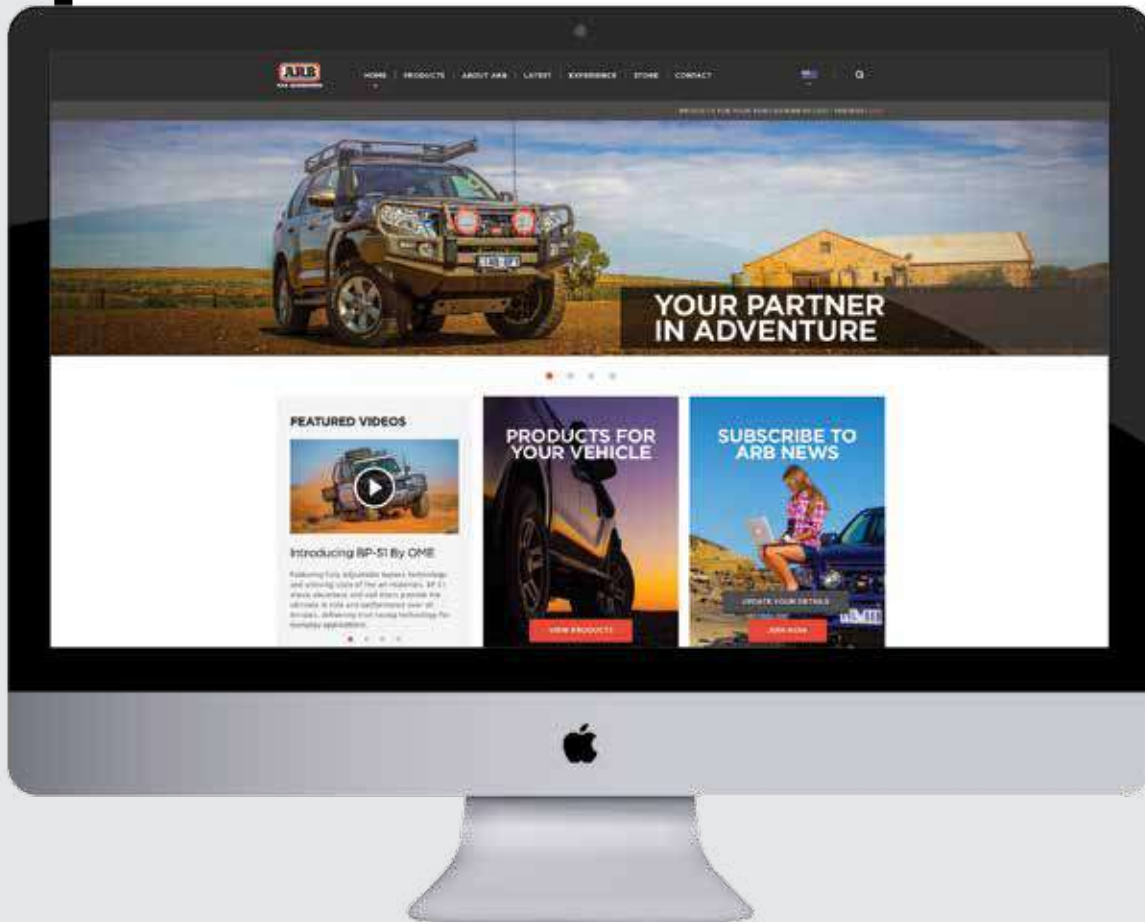

The website has been upgraded to improve user friendliness and appeal, with new functions implemented and based on extensive research and customer feedback.

ARB's reputation for breathtaking, high quality imagery is utilised throughout the redesign, with large hero banners and art directed photography. A greater use of videos and interactive tools not only ensures a clearer understanding of our thoroughly engineered products, but provides a more exciting and enjoyable user experience.

Totally responsive to devices, the new website will intelligently resize, based upon the device you are viewing it from, eliminating the often frustrating feature of mobile versions that omit much of the vital information found on the desktop site. This feature is compatible with all iOS and Android tablets and smart phones.

The improved "Customise your vehicle" section allows you to select your vehicle, and provides an extensive insight into the products available for your particular make and model, plus the addition of beautiful imagery, gives a clear idea on how these products will improve the aesthetics and functionality of your 4WD.

The new website also includes up to date pricing

for all ARB products, easily accessed through a downloadable PDF document.

An added blog section provides current information on new product releases and product information, as well as interesting travel articles, tips and techniques and ARB behind the scenes insights.

Containing over 1,200 redesigned pages, the new website retains many of the previous website's most popular features including:

- Extensive and detailed product information.
- ARB history and careers
- Calendar of events
- Downloadable catalogue and latest editions of ARB 4x4 Action magazine
- Free downloadable wallpapers
- ARB kids
- ARB promotional store
- Company policies, investor relations and testimonials
- ARB press room

**Jump online and check it out –
www.arb.com.au**





A photo from my great adventure in Uyuni Bolivia. Christopher Morales



Bog hole check, Wombat State Forest, VIC. Rodney Harris



Camping in the Simpson Desert. Wendy Warren



THE LATEST OFF ROAD
PHOTOS FROM OUR READERS
LIVING THE DREAM!

Exploring One Mile Beach, NSW. Kirsten Hickey

SCRUB UP COMPETITION



Camerons Corner Crew, jumping for joy! Bronwyn Payne



Fresh water camp shower at Byfield National Park, QLD. **Mark Butters**



Getting muddy on the way to Cape York. Ben McCarthy



Here is my LPG hot shower setup using a stainless steel mixing bowl and a copper pipe coil all mounted on a gas burner. I use a 12v bilge pump to move the water. Get the gas right and you have continuous hot water (at least until your water drum runs dry).

Adam Edwards



VICTORIA

Kilsyth	(03) 9761 6622
Brighton	(03) 9557 1888
Dandenong	(03) 9793 0002
Hoppers Crossing	(03) 9749 5905
Keilor Park	(03) 9331 7333
Pakenham	(03) 5940 5500
Thomastown	(03) 9460 9988
Bairnsdale	(03) 5152 1226
Ballarat	(03) 5331 7078
Bendigo	(03) 5445 7100
Geelong	(03) 5229 3910

SOUTH AUSTRALIA

Regency Park	(08) 8244 5001
Morphett Vale	(08) 8186 6101
Elizabeth	(08) 8252 1599

ACT

Fyshwick	(02) 6280 7475
----------	----------------

NEW SOUTH WALES

Moorebank	(02) 9821 3633
Artarmon	(02) 9438 4484
St Peters	(02) 9565 2455
Wentworthville	(02) 9631 7889
Albury	(02) 6021 2477
Broken Hill	(08) 8087 9250
Dubbo	(02) 6885 5777
Newcastle	(02) 4953 9555
Orange	(02) 6369 0700
Penrith	(02) 4731 1266
Port Macquarie	(02) 6581 2500
Tamworth	(02) 6762 0541
Wollongong	(02) 4227 1900

WESTERN AUSTRALIA

Canning Vale	(08) 6254 2367
Osborne Park	(08) 9244 3553
Wangara	(08) 9409 5764
Welshpool	(08) 9358 3688
Mandurah	(08) 9583 3200

NORTHERN TERRITORY

Winnellie	(08) 8947 2262
Alice Springs	(08) 8953 0572

QUEENSLAND

Nundah	(07) 3266 3255
Capalaba	(07) 3823 5900
Coopers Plains	(07) 3277 2020
Biggera Waters	(07) 5537 8800
Bundaberg	(07) 4153 2929
Burleigh Heads	(07) 5535 9223
Caboolture	(07) 5499 1955
Cairns	(07) 4035 3350
Mackay	(07) 4998 6888
Maroochydore	(07) 5475 4011
Rockhampton	(07) 4922 7788
Toowoomba	(07) 4632 1122
Townsville	(07) 4728 0900

TASMANIA

Burnie	(03) 6431 4494
Launceston	(03) 6331 4190
Hobart	(03) 6228 6822

HEAD OFFICE:**ARB 4X4 ACCESSORIES**

42-44 Garden Street,
Kilsyth Victoria 3137 Australia
Tel: (03) 9761 6622
Fax: (03) 9761 6807
Email: sales@arb.com.au
Web: www.arb.com.au

